

Aeromob Equipamentos Aeronáuticos Ltda

CNPJ: 40.061.679/0001-43

Address: 990 Carlos Willy Boehm St.

Costa e Silva - Joinville - SC

ZIP code: 89218-325

Phone number: +55 47 4101- 2724 | +55 47 9 9937- 9077

Visit our website [www.aeromob-industry.com](http://www.aeromob-industry.com)

Contact us for more information about spare parts and products.

---

## INTRODUCTION

The Illustrated Parts Catalog (IPC) must be used to identify parts and component replacement request. The IPC should never be used as a component removal, installation and maintenance procedure. This catalog is used in conjunction with the Equipment Maintenance Manual (MM). The structure of chapters and details used in this IPC follow the applicable standards as Air Transport Association (ATA) SPEC 100 and iSPEC 2200.

The catalog features:

1. A list of chapters;
2. An isometric view of the equipment with emphasis on the set shown in the chapter;
3. An exploded view of each equipment set and its respective list of components;
4. The numbering of the pages is composed initially by the number of the chapter and followed by chapter page number.

### PART DESIGNATION

AEROMOB parts are designated using the following code:

**AM-HDM-135-S01**

such that,

**AM:** AEROMOB

**HDM:** Represents the family of equipment

**135:** the equipment model

**S01:** represents the part-specific code.

On standard components purchased from third parties such as screws bearings, etc., the codes are varied, according to the necessary specification in each item. In some cases, manufacturers codes are also used.

AEROMOB special tools are designated with an "FM" prefix keeping then the identification code of the equipment to which it is applied.

## INTRODUCTION

### PARTS AVAILABILITY

"YES" indicates the part is available as a separate replacement item.

"NO" indicates that the part is no longer available or is only available as part of a set.

### ABBREVIATIONS

BICR - Bichromated  
CL - Class  
DISP - Parts availability  
SS - Stainless steel  
HS - Hexagon socket  
WS - Worm shaft  
TS - Top Shaft

### WARRANTY

AEROMOB applies the standard 1-year warranty on parts and components purchased from AEROMOB or an authorized dealer.

### RETURNS

No unused parts may be returned to AEROMOB for credit if the parts show any indication of wear or damage, or if the cost of the individual part is less than \$25 (US). Parts returned within 30 days of purchase will be valued at a 20% restocking fee. no part may be returned after 30 days without AEROMOB's prior approval. Any parts approved for return after 30days will be evaluated at a fee 50% restocking fee.

## INTRODUCTION

This document is copyrighted. The total or partial copy of the text, images or tables without the authorization of AEROMOB is expressly prohibited, subjecting the violator to the appropriate civil and criminal penalties.

## REVISION

Revision Number	Date

To access the updated version of this document,  
point your device at the QR CODE below.



[www.aeromob.com.br/support-am-rdm-505L-k02](http://www.aeromob.com.br/support-am-rdm-505L-k02)

**SUMMARY**

CHAPTER 1 - LEFT BODY .....	1-1
BILL OF MATERIALS .....	1-2
RIGHT BODY .....	1-3
BILL OF MATERIALS .....	1-4
CHAPTER 2 - ARM .....	2-1
BILL OF MATERIALS .....	2-2
CHAPTER 3 - WHEEL .....	3-1
BILL OF MATERIALS .....	3-2
CHAPTER 4 - LEVER BAR .....	4-1
BILL OF MATERIALS .....	4-2

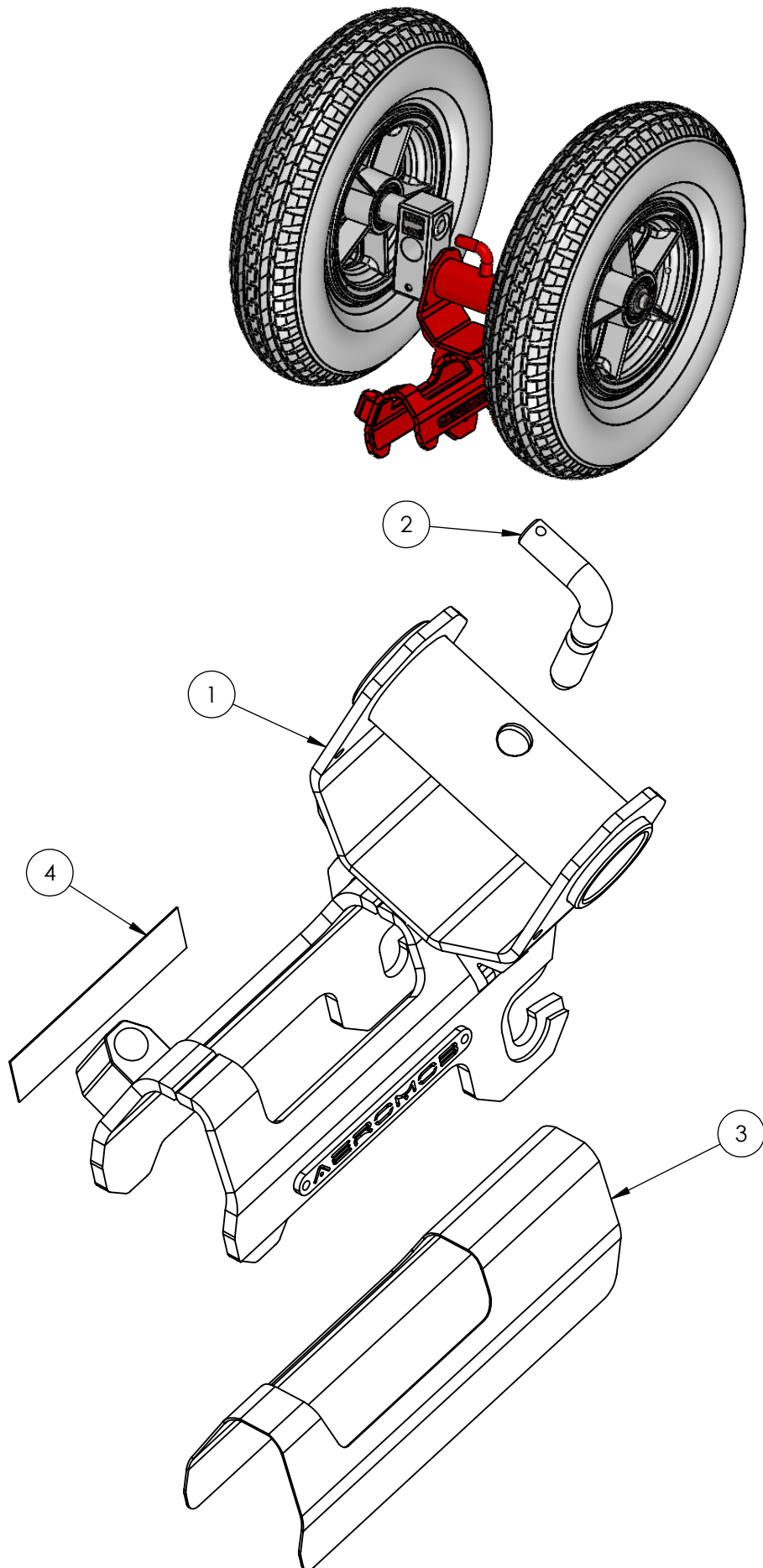

POS	ACTIVE PN	DESCRIPTION	QTY IN THIS DRAWING	QTY EQUIPMENT	OLD PN	APPLICABLE TO SN	AVAIL
1	AM-RDM-505L-S01	LEDFT WELDED BODY	1	1	---	ALL	---
2	AM-RDM-505H-009	LOCK PIN	1	2	---	ALL	---
3	AM-RDM-505L-012	ANTI-ABRASIVE PROTECTION	1	2	---	ALL	---
4	AM-RDM-505L-011	ID PLATE	1	2	---	ALL	---

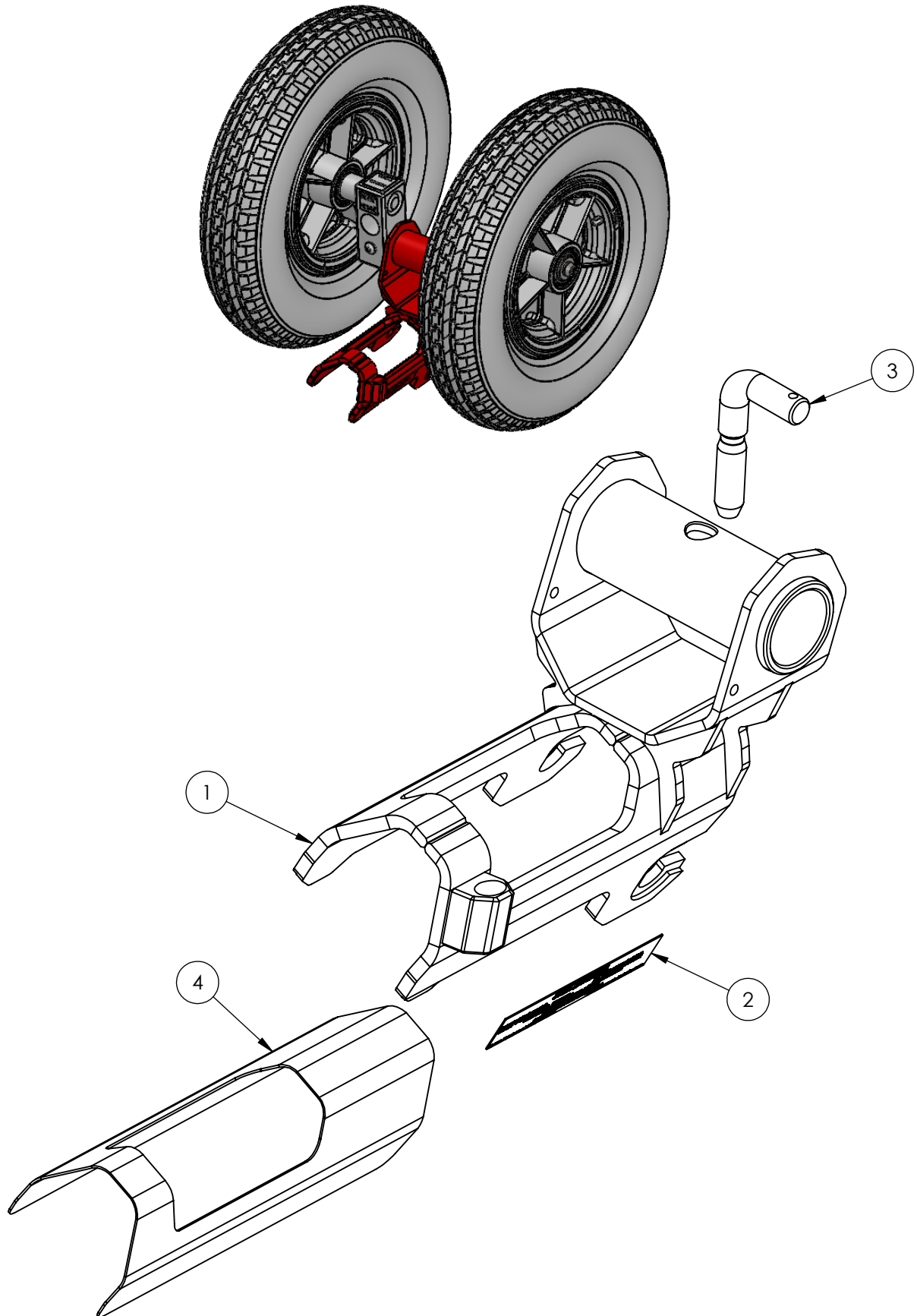

POS	ACTIVE PN	DESCRIPTION	QTY IN THIS DRAWING	QTY EQUIPMENT	OLD PN	APPLICABLE TO SN	AVAIL
1	AM-RDM-505L-S02	RIGHT WELDED PROTECTION	1	1	---	ALL	---
2	AM-RDM-505L-011	ID PLATE	1	2	---	ALL	---
3	AM-RDM-505H-009	LOCK PIN	1	2	---	ALL	---
4	AM-RDM-505L-012	ANTI-ABRASIVE PROTECTION	1	2	---	ALL	---

### CHAPTER 2 - ARM

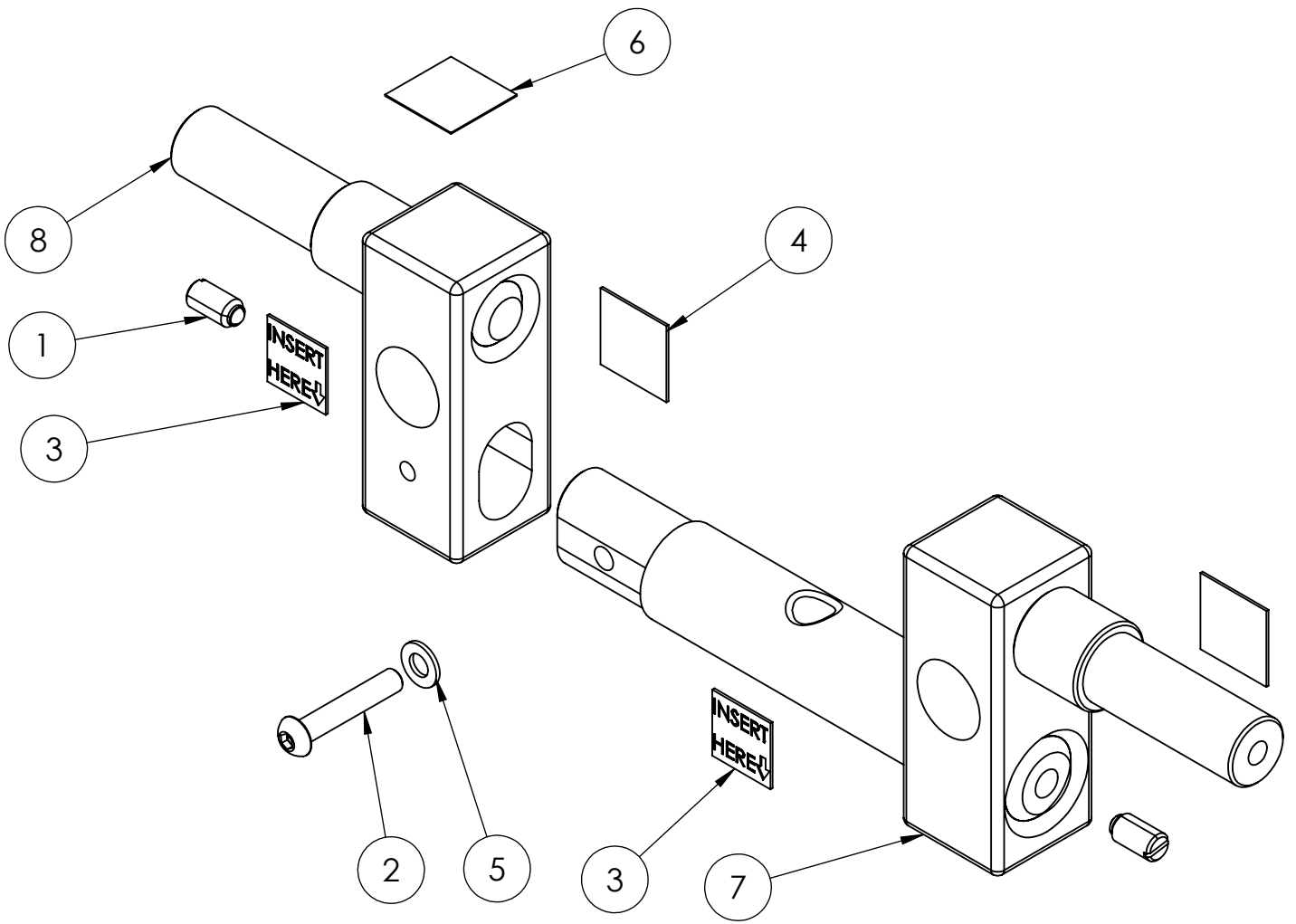
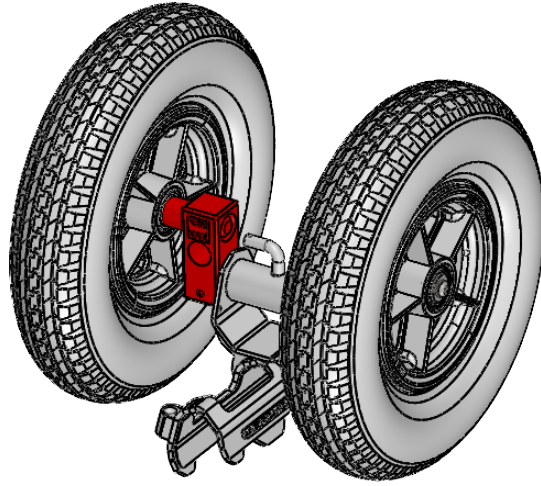

POS	ACTIVE PN	DESCRIPTION	QTD.	QTY EQUIPMENT	OLD PN	APPLICABLE TO SN	AVAIL
1	INDEX GN615M10KN	SPRING BALL PLUNGER	2	4	---	ALL	---
2	DIN7380 M8X45	SS - HS BUTTON H SCREW M8 x 45	1	2	---	ALL	---
3	AM-PLQ-001	INSERT PLATE	2	4	---	ALL	---
4	AM-PLQ-002	X PLATE	2	4	---	ALL	---
5	INOX DIN125 M8	SS - FLAT WASHER M8	1	2	---	ALL	---
6	QR CODE AM-RDM- 505L-K02	QR CODE PLATE	1	1	---	ALL	---
7	H125_S01	MAIN AXLE WELDED	1	2	---	ALL	---
8	H125_S04	AUXILIARY AXLE	1	2	---	ALL	---

### CHAPTER 3 - WHEEL

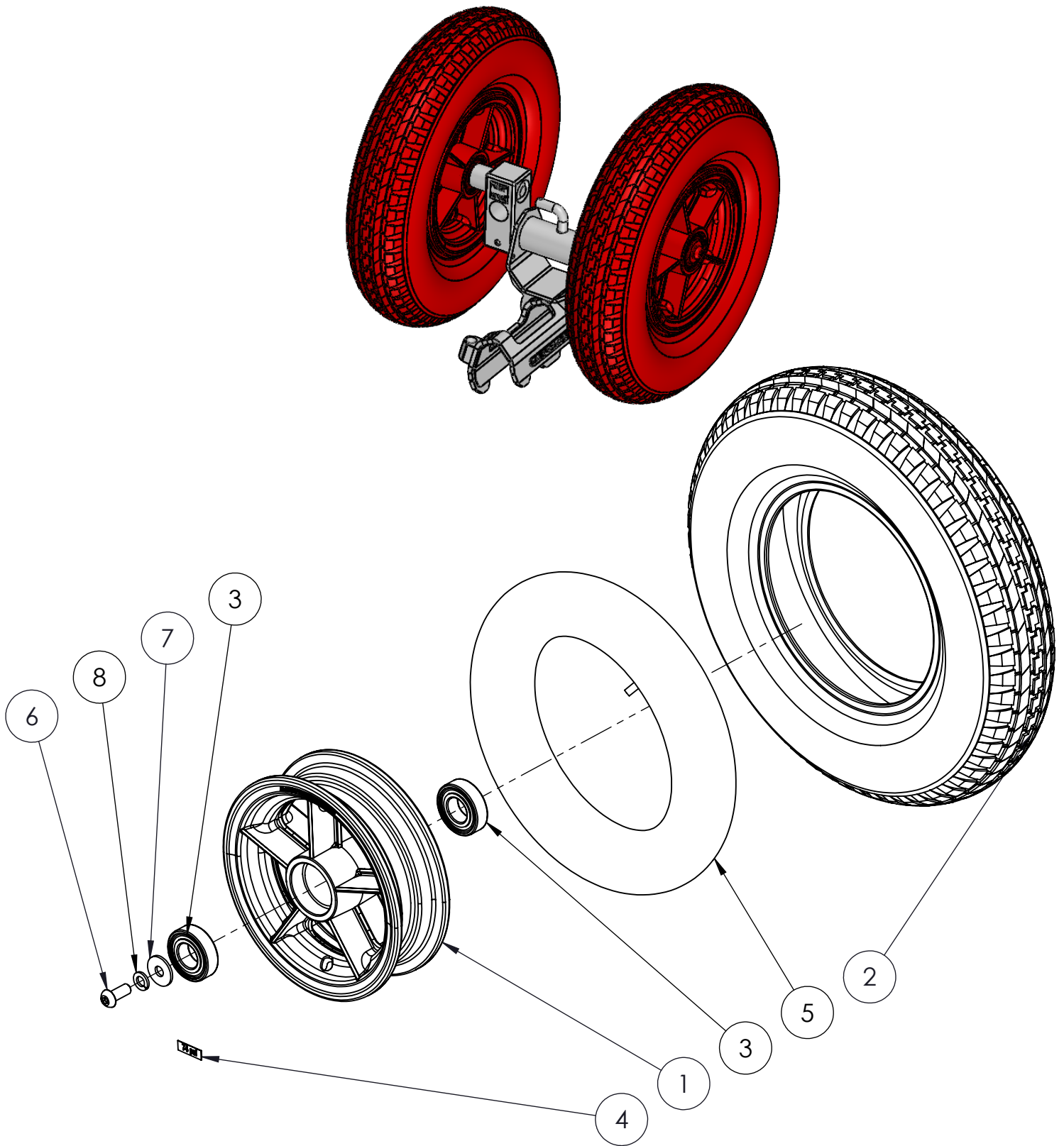

POS	ACTIVE PN	DESCRIPTION	QTY IN THIS DRAWING	QTY EQUIPMENT	OLD PN	APPLICABLE TO SN	AVAIL
1	ARO-8P-AMB	AEROMOB RIM 8 IN	1	4	---	ALL	---
2	PNEU 4.8/4.0/8	TIRE 4.8/4.0/8	1	4	---	ALL	---
3	ROL 6205-2RS	BALL BEARING 6205-2RS	2	8	---	ALL	---
4	AM-PLQ-004	74 PSI PLATE	2	4	---	ALL	---
5	CA 8 POL	AIR CHAMBER 8 IN	1	4	---	ALL	---
6	INOX DIN7380 M10X25	SS - SCREW H BUTTON HEX INT M10X25	1	4	---	ALL	---
7	INOX DIN9021 M10	SS - LARGE FLAT WASHER M10	1	4	---	ALL	---
8	INOX DIN127 M10	SS - SPLIT LOCK WASHER M10	1	4	---	ALL	---

### CHAPTER 4 - BIPARTED LEVER BAR

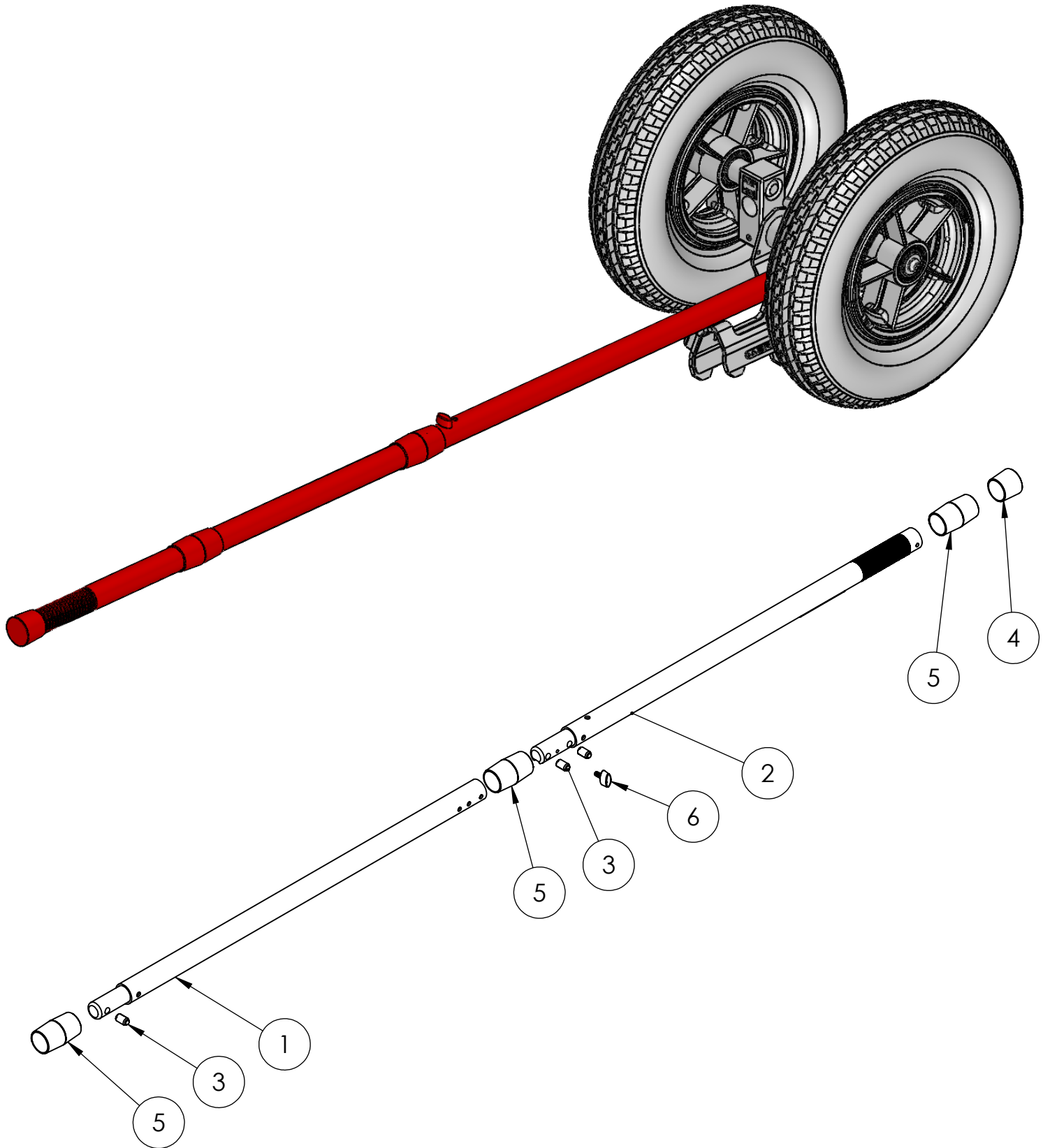

### HELIMOB 505L

### IPC-AM-RDM-505L-K02

POS	ACTIVE PN	DESCRIPTION	QTY IN THIS DRAWING	QTY EQUIPMENT	OLD PN	APPLICABLE TO SN	AVAIL
1	H125_S07	LOWER LEVER BAR	1	1	---	ALL	---
2	H125_S08	UPPER LEVER BAR	1	1	---	ALL	---
3	INDEX GN615M12KN	SS - SPRING PLUNGER GN615- M12-KN	3	3	---	ALL	---
4	TAMP33	END COVER CAP 33mm	1	1	---	ALL	---
5	TAMP33U	CUTTED END COVER CAP 33mm	6	6	---	ALL	---
6	BTM 2613 M6X15	MALE LOCK BUTTON M6X15	1	1	---	ALL	---