

EQUIPMENT MANUFACTURER: AEROMOB HELICOPTER PARTS INDUSTRY

EQUIPMENT NAME: AEROLADDER 429

EQUIPMENT DESCRIPTION: CARBON FIBER LADDER FOR ACCESSIBILITY OF PASSENGERS WITH REDUCED MOBILITY AND VIPs.

EQUIPMENT PART NUMBER: AM-LDR-429-K01

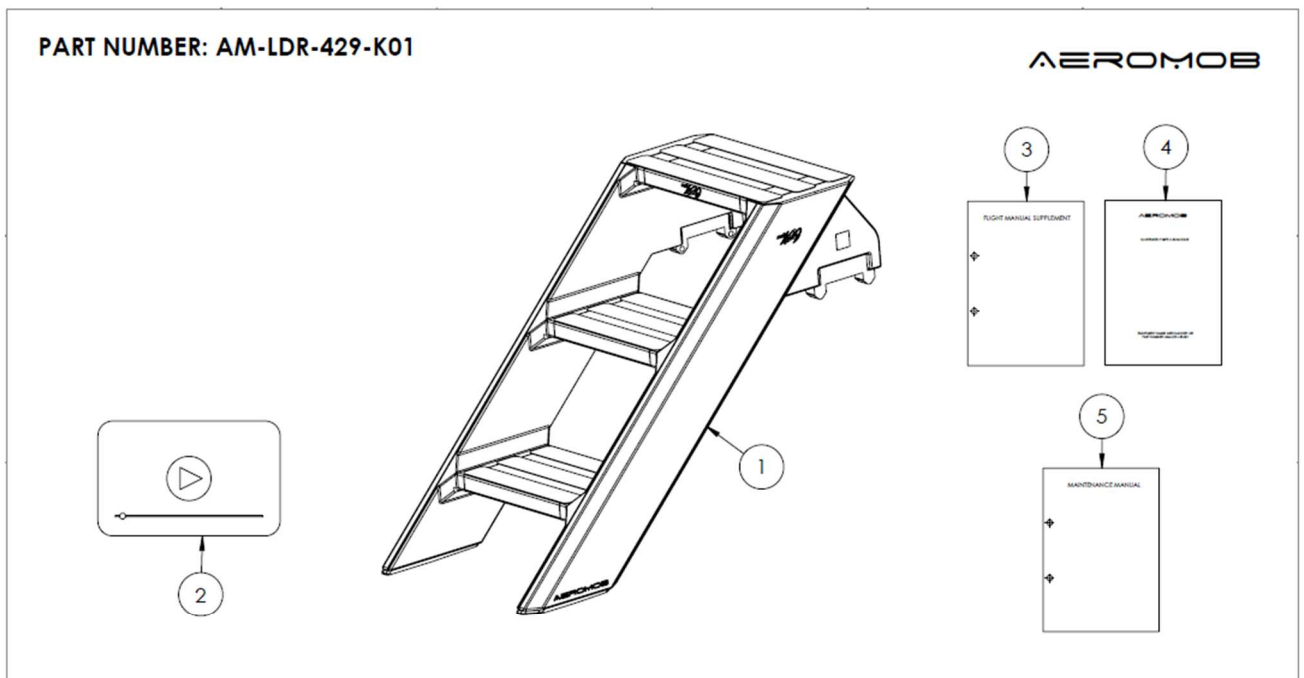

**ITEMS OF THE PART NUMBER: AM-LDR-429-K01**

ITEM NUMBER	DESCRIPTION	PART NUMBER	QTY
1	AEROLADDER 429	AM-LDR-429-M01	1
2	VIDEO MANUAL (MP4)	UVM-AM-LDR-429-K01	1
3	FLIGHT MANUAL SUPPLEMENT - FMS	FMS-AM-LDR-429-K01	1
4	ILLUSTRATED PARTS CATALOGUE - IPC	IPC-AM-LDR-429-K01	1
5	MAINTENANCE MANUAL - MM	MM-AM-LDR-429-K01	1

**APPROVED USE**

The equipment AEROLADDER 429, has the function of accessibility for helicopters passengers. The AEROLADDER 429 is intended for use on Bell 429 helicopters in all versions, including versions with floats installed. The use of such equipment in other helicopter models or for functions not approved in this manual is expressly prohibited.

**GENERALITIES**

- Monoblock construction in flameproof carbon fiber
- Total ladder weight: 6 lb / 2.8 kg

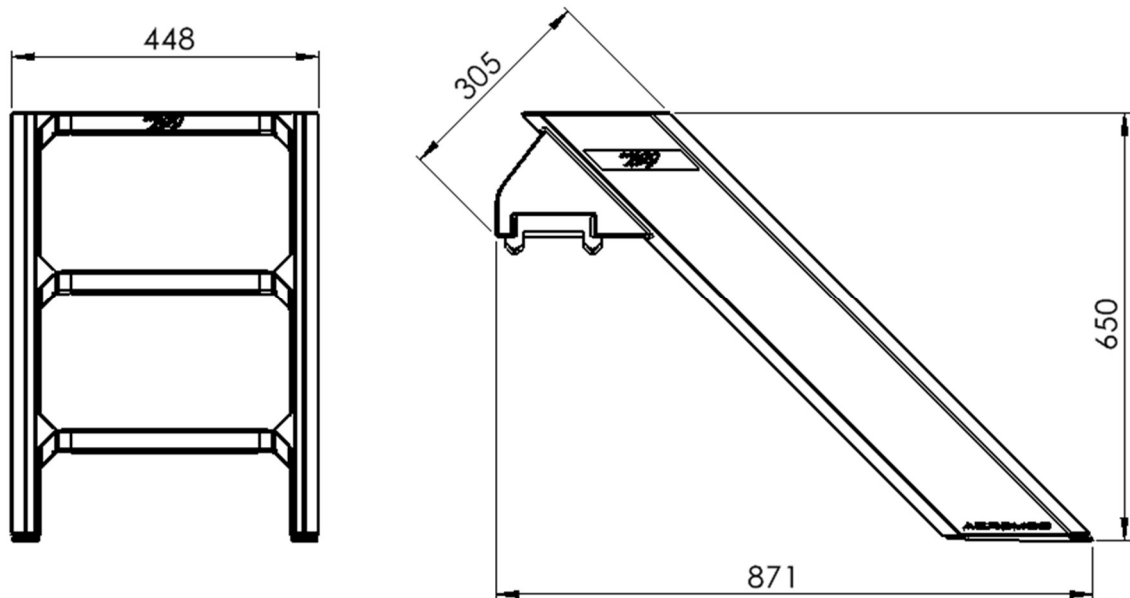
**LIMITATIONS**

- Approved for passengers up to 287lb / 130kg and using a maximum of 1 (one) passenger at a time for the exclusive use of boarding and disembarking.
- As for the type of surface approved, the AEROLADDER 429 can be used on paved floors, firm grass or firm beaten ground, being allowed the installation of the equipment in the aircraft on soils with up to 5% of inclination. Use on uneven terrain that leaves the ladder poorly supported is prohibited.
- Only the use of the equipment is allowed, being the complete set and in perfect operation. It is expressly prohibited and dangerous to use the equipment with any part, information board, missing component or using a component that is not part of this set and/ or has not been provided by the manufacturer. If any item or component needs to be replaced, contact the manufacturer.

**INSTRUCTIONS FOR USE**

The operational use of the equipment must be carried out in accordance with the User Manual Video, part number VM-AM-LDR-429-K01.

To get access the updated version of the User Manual, access the link: <https://www.aeromob-industry.com/pt/support-am-ldr-429-k01> or just scan the QR CODE available in this FMS.

Basic operational description:

The ladder must be completely fitted into the Aircraft's Footstep, compatible with the passenger exit door.

**DANGER:** Never use the ladder to board or disembark without ensuring that the ladder is fully engaged in the Footstep and that both feet of the ladder are in contact with the ground. **ATTENTION:** The function of the basic description is for guidance purposes only, and full use of the information available in the Video User Manual as referenced in this FMS is mandatory before any use of the equipment.

### **REQUIRED MAINTENANCE**

The revision plan and any necessary maintenance procedure must be carried out in accordance with the equipment maintenance manual (MM-AM-LDR-429-K01) to be accessed in the QR CODE available in this FMS. To get access the latest version of Maintenance Manual, access the link <https://www.aeromob-industry.com/pt/support-am-ldr-429-k01> or just scan the QR CODE available in this FMS.

### **SPARE PARTS**

Illustrated Parts Catalogue – IPC is the official inquiry document for ordering replacement parts, part number document IPC-AM-LDR-429-K01.

To get access the latest version of IPC, access the link <https://www.aeromob-industry.com/pt/support-am-ldr-429-k01> or just scan the QR CODE available in this FMS.

### **WARRANTY**

Your equipment has a 1 (year) warranty and, if necessary, it can be requested directly from AEROMOB through the link: [www.aeromob-industry.com/support-am-ldr-429-k01](http://www.aeromob-industry.com/support-am-ldr-429-k01), or just scan the QR CODE available in this FMS.

### **RECOMMENDATIONS**

- Highly important equipment for **Helicopters with Floats**, as it protects the floats against daily knocks when used as boarding and disembarking steps by passengers, which creates a high risk of hidden damage to the safety flotation system.

**ACCESS TO ALL NECESSARY DOCUMENTATION**

Below, see list of files and documents available to the customer of this equipment and the QR CODE for access to the always updated version:

**(PN FMS-AM-LDR-429-K01) FLIGHT SUPPLEMENT MANUAL**

**(PN UVM-AM-LDR-429-K01) USER VIDEO MANUAL**

**(PN MM-AM-LDR-429-K01) MAINTENANCE MANUAL**

**(PN IPC-AM-LDR-429-K01) ILLUSTRATED PARTS CATALOGUE**



[www.aeromob.com.br/support-am-ldr-429-k01](http://www.aeromob.com.br/support-am-ldr-429-k01)