

EQUIPMENT MANUFACTURER: AEROMOB HELICOPTER PARTS INDUSTRY

EQUIPMENT NAME: AEROLADDER 145 K01

EQUIPMENT DESCRIPTION: CARBON FIBER LADDER TO ACESSIBILITY OF REDUCED MOBILITY PASSENGERS AND VIP's.

EQUIPMENT PART NUMBER: AM-LDR-145-K01

PART NUMBER: AM-LDR-145-K01

AEROMOB

ITEMS OF PART NUMBER: AM-LDR-145-K01

ITEM NUMBER	DESCRIPTION	PART NUMBER	QTY
1	AEROLADDER145	AM-LDR-145-MT1	1
2	CARRYING STRAP	AM-LDR-145-M03	2
3	VIDEO MANUAL - CARRYING STRAP (MP4)	UVM-AM-LDR-145-K01	1
4	FLIGHT MANUAL SUPPLEMENT - FMS	FMS-AM-LDR-145-K01	1
5	ILLUSTRATED PARTS CATALOGUE - IPC	IPC-AM-LDR-145-K01	1
6	MAINTENANCE MANUAL - MM	MM-AM-LDR-145-K01	1

APPROVED USE

The AEROLADDER 145 K01 equipment has the function of an accessibility ladder for boarding and disembarking passengers and is approved for use on the helicopter models: Airbus H145 C2, Airbus H145 D2 and Airbus H145 D3 helicopters, in all their versions, including versions with floats installed.

The equipment is approved for passengers up to 287lb / 130kg, with the maximum of 1 (one) passenger at a time and for the exclusive use of boarding and disembarking the aircraft.

The use of this equipment on other helicopter models, people above the approved weight and/or for unapproved functions, is expressly prohibited.

GENERAL

- Mono-block construction in flame-retardant carbon fiber
- Total ladder weight: 6lb / 2.8kg

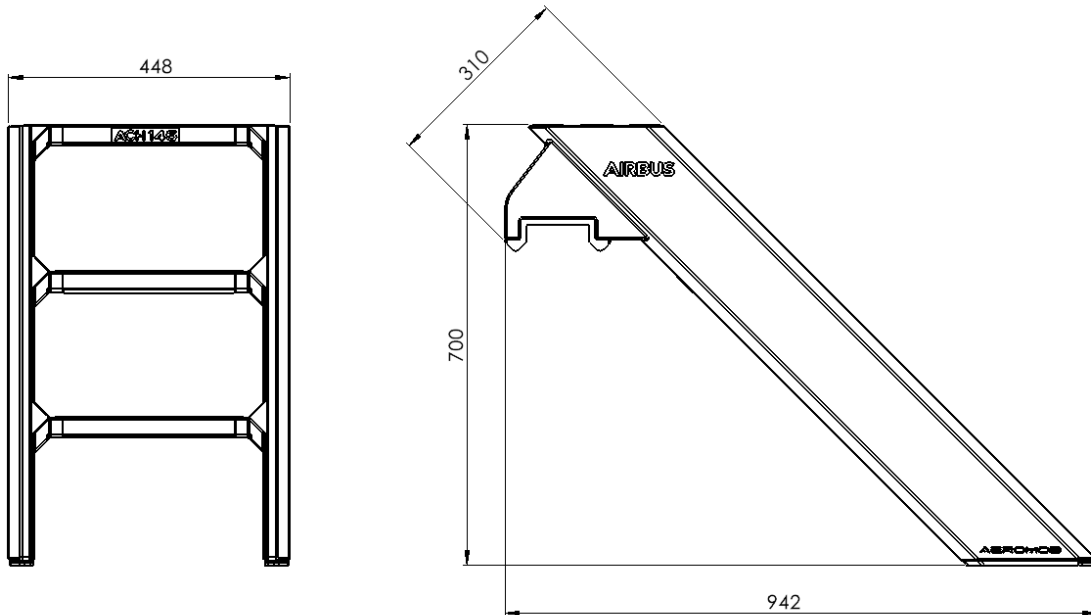

RESTRICTIONS

- Regarding the type of approved surface, the AEROLADDER 145 K01 can be used on paved floors, firm grass or firm dirt ground, with installation of the equipment on the aircraft permitted on soils with up to a 5% slope. Use on uneven ground that leaves the ladder poorly supported is prohibited.
- The use of the equipment is only permitted if the set is complete and in perfect working condition.
- It is strictly prohibited and dangerous to use the equipment with any part, information plate, missing component or using a component that is not part of this set or that has not been supplied by the manufacturer. If the replacement of any item or component is necessary, contact the manufacturer.

USE INSTRUCTIONS

The operational utilization of the equipment must be in agreement with the instructions in the User Manual Video, part number VM-AM-LDR-145-K01.

To access the updated version of the User Manual, access the link: <https://www.aeromob-industry.com/support-am-ldr-145-k01> or just scan the QR CODE available in this FMS.

Basic operational description:

The ladder must be completely fitted onto the Aircraft Foot Step, aligned with the passenger exit door.

DANGER: Never use the ladder for boarding or disembarking without ensuring that the ladder is fully engaged in the Foot Step and that the feet of the ladder are in contact with the ground.

ATTENTION: The function of the basic description is for guidance purposes only, being mandatory full use of the information available in the User Manual Video as referenced in this FMS before any use of the equipment.

REQUIRED MAINTENANCE

The overhaul plan and any necessary maintenance procedures must be performed in accordance with the maintenance manual, document part number MM-AM-LDR-145-K01.

To access the updated version of the Maintenance Manual, access the link: <https://www.aeromob-industry.com/support-am-ldr-145-k01> or just scan the QR CODE available in this FMS.

SPARE PARTS

The Illustrated Parts Catalog - IPC is the official reference document for ordering spare parts, part number document IPC-AM-LDR-145-K01

To access the updated version of the Illustrated Parts Catalog, access the link: <https://www.aeromob-industry.com/support-am-ldr-145-k01> or just scan the QR CODE available in this FMS.

WARRANTY

Your equipment has a 1 (year) warranty and, if necessary, it can be requested directly from AEROMOB through the link: www.aeromob.com.br/support-am-ldr-145-k01 or by scanning the QR CODE available in this FMS.

RECOMMENDATIONS

- Highly important equipment for Helicopters with Floats, as it protects the floats against daily stress when used as boarding and disembarking steps by passengers, which creates a high risk of hidden damage to the safety buoyancy system.
- If you have SCT nº 2019S10-05 ANAC applied, use the clips fixed to the roof of the luggage compartment to better secure your ladder and thus not leave it loose among the luggage, which allows you not to take up useful space in the luggage compartment of the Airbus H145 and leaves the ladder available as the first item after landing.

ACCESS TO ALL UPDATED DOCUMENTATION

Below is a list of files and documents available to the customer of this equipment and the QR CODE for access to the always up-to-date version:

(PN FMS-AM-LDR-145-K01) SUPPLEMENT TO THE FLIGHT MANUAL

(PN UVM-AM-LDR-145-K01) USER MANUAL VIDEO

(PN MM-AM-LDR-145-K01) MAINTENANCE MANUAL

(PN IPC-AM-LDR-145-K01) ILLUSTRATED PARTS CATALOG



www.aeromob-industry.com/support-am-ldr-145-k01