

EQUIPMENT MANUFACTURER:

AEROMOB HELICOPTER PARTS INDUSTRY

Rua Carlos Willy Boehm, 990

89218-325

Costa e Silva

Joinville/SC – Brazil

ORIGINAL INSTRUCTIONS

EQUIPMENT NAME:

HARDMOB 135

MODEL:

K01

MACHINERY DESIGNATION:

HELICOPTER WHEELS

EQUIPMENT PART NUMBER:

AM-HDM-135-K01

LANGUAGE:

ENGLISH

INTENTIONALLY LEFT BLANK

Written by Date: MATEUS FREITAS 24/OUT/24	Approved by Date: PHIL XAVIER 25/OUT/24
Updated by Date: MATEUS FREITAS 04/DEC/24	Approved by Date: PHIL XAVIER 04/DEC/24

1 INTRODUCTION

The equipment you are receiving was developed under the most advanced engineering concept. Congratulations on your operational choice!

This manual contains instructions and approved operating procedures for using the HARDMOB 135, the set of wheels for aircraft movement developed for the Airbus H135.

This User Manual is a mandatory read by anyone wishing to operate the equipment, assuring quality and safety in the operation.

In addition to this User Manual, your equipment is accompanied by the following documents: Flight Manual Supplement (FMS), Maintenance Manual (MM) and Illustrated Parts Catalog (IPC). For more information on these documents, as well as on Warranty and Support, see chapters 8 and 9 of this manual.

INTENTIONALLY LEFT BLANK

Written by Date: MATEUS FREITAS 24/OUT/24	Approved by Date: PHIL XAVIER 25/OUT/24
Updated by Date: MATEUS FREITAS 04/DEC/24	Approved by Date: PHIL XAVIER 04/DEC/24

2 GENERAL INFORMATION

The dimensions of the HARDMOB 135, PART NUMBER AM-HDM-135-K01, as well as the list of the accompanying documentation, are shown below. The weight of each wheel is 25.2 kg, the weight of each lever is 1.5 kg, for a total of 53.4 kg for the complete set.

PART NUMBER: AM-HDM-135-K01

ITEMS OF THE PART NUMBER: AM-HDM-135-K01			
ITEM NUMBER	DESCRIPTION	PART NUMBER	QTY.
1	LEFT GROUND HANDLING WHEEL	AM-HDM-135-MT1	1
2	RIGHT GROUND HANDLING WHEEL	AM-HDM-135-MT2	1
3	LEVER BAR	AM-HDM-135-M04	2
4	USER MANUAL (PDF)	UM-AM-HDM-135-K01	1
5	FLIGHT MANUAL SUPPLEMENT - FMS	FMS-AM-HDM-135-K01	1
6	ILLUSTRATED PARTS CATALOGUE - IPC	IPC-AM-HDM-135-K01	1
7	MAINTENANCE MANUAL - MM	MM-AM-HDM-135-K01	1

The documentation accompanying the product can be accessed via the link www.aeromob-industry.com/support-am-hdm-135-k01 or by scanning the QR CODE available in this Manual.

Written by Date: MATEUS FREITAS 24/OUT/24	Approved by Date: PHIL XAVIER 25/OUT/24
Updated by Date: MATEUS FREITAS 04/DEC/24	Approved by Date: PHIL XAVIER 04/DEC/24

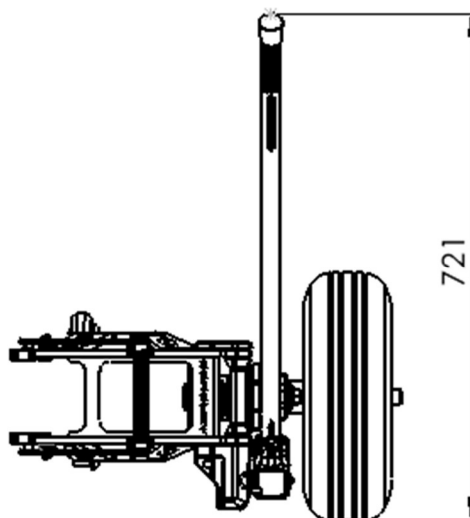
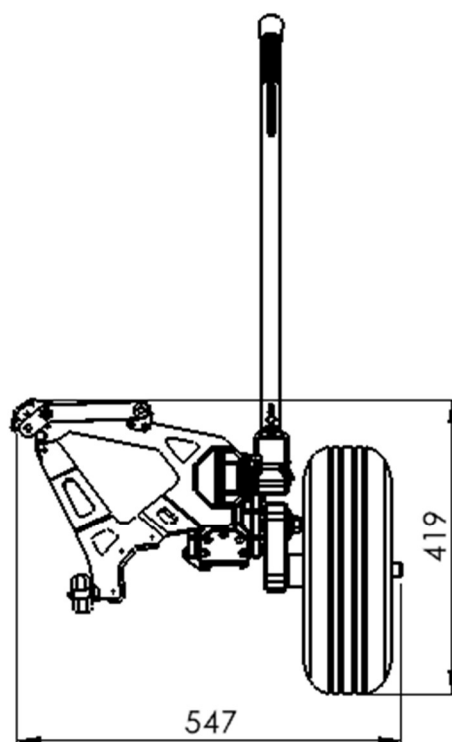
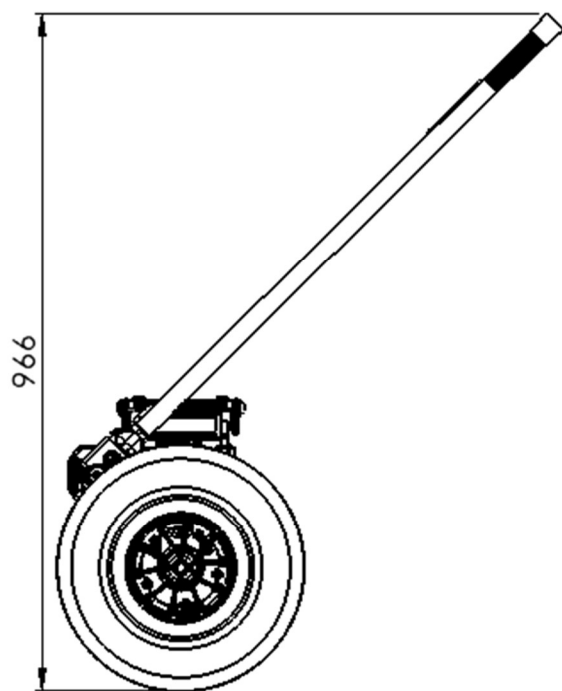

Weight of each wheel: 25.2 kg

Weight of each lever: 1.5 kg

Total equipment weight: 53.4 kg

3 APPROVED USE

The wheel pair (PN AM-HDM-135-K01) is operationally approved for suspending and manoeuvring Airbus H135 helicopters, with a maximum weight of 3,100 kg/6,834lbs. The Airbus H135 helicopter features three different skid heights: low, intermediate and high. The equipment is approved for use on these three skid versions of the Airbus H135.

It is expressly forbidden to use this equipment on other helicopter models, above the approved weight and/or for non-approved functions.

Written by Date: MATEUS FREITAS 24/OUT/24	Approved by Date: PHIL XAVIER 25/OUT/24
Updated by Date: MATEUS FREITAS 04/DEC/24	Approved by Date: PHIL XAVIER 04/DEC/24

4 LIMITATIONS

The tires must be calibrated to 120 psi (8.3 bar). All 2 tires of the set must be calibrated before using the equipment. If there is a variation in ambient temperature larger than 10°C from the day of calibration to the time the equipment is used, the tires may lose their calibration and must therefore be recalibrated before use.

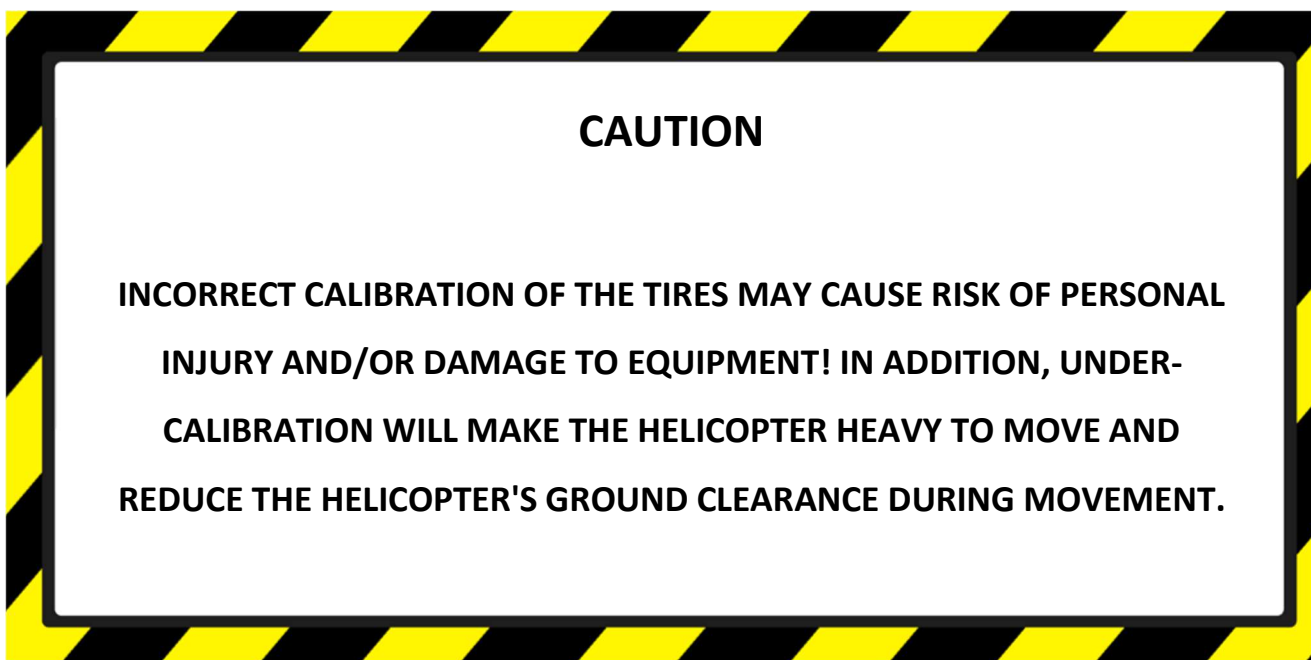

A minimum of two operators is required to lever and lift the aircraft, with one person responsible for levering and the other for safeguarding the helicopter's tail from the risk of tipback. The tendency for the tail to droop will depend on the level of the ground, as well as the position of the aircraft's Center of Gravity at the time, which will vary depending on the amount of equipment installed in the aircraft, fuel supplied and the basic empty CG of your helicopter. To move the aircraft with human power, at least three people are needed, one person to hold the helicopter by the tail and two others to push the aircraft.

Operation of this equipment with people or luggage aboard the aircraft is prohibited. The set has a load capacity of 3,100 kg/6,834lbs, distributed over the pair of wheels.

Use of this equipment is approved for paved surfaces, firm grass or firm beaten ground, and installation of the equipment and movement of the aircraft on ground with a slope of up to 5% is permitted. Use on uneven terrain, which causes severe shaking or jolting, is not permitted, as it could pose a risk of damage to the aircraft and/or operators near the aircraft.

Handling is limited to walking speed when propelled by human power, and up to 6 km/h (3.7mph) when the aircraft is being towed by a motorized vehicle. For towing the suspended aircraft using a

Written by Date: MATEUS FREITAS 24/OUT/24	Approved by Date: PHIL XAVIER 25/OUT/24
Updated by Date: MATEUS FREITAS 04/DEC/24	Approved by Date: PHIL XAVIER 04/DEC/24

motorized vehicle, it is recommended to use the original CARTMOB tow bar (PN AM-CRT-K02) from AEROMOB, due to its height, which favors forward CG for the aircraft during towing.

The equipment may only be used complete and in perfect working order. It is strictly forbidden and dangerous to use the equipment if any part, information plate or component is missing. If any item or component needs to be replaced, contact the manufacturer.

It is strictly forbidden and dangerous to use the equipment with any part or component that is not part of this set and/or has not been supplied by the manufacturer.

5 BASIC OPERATIONAL DESCRIPTION

5.1 LEVER BAR ATTACHMENT

To ensure the safe shipment of the HARDMOB 135, the lever bar is shipped detached from the handle. To attach the lever to the handle, insert it in the place indicated on the handle. Once attached, there is no need to detach the lever, and it can remain attached to the equipment for all use, including while handling the aircraft.

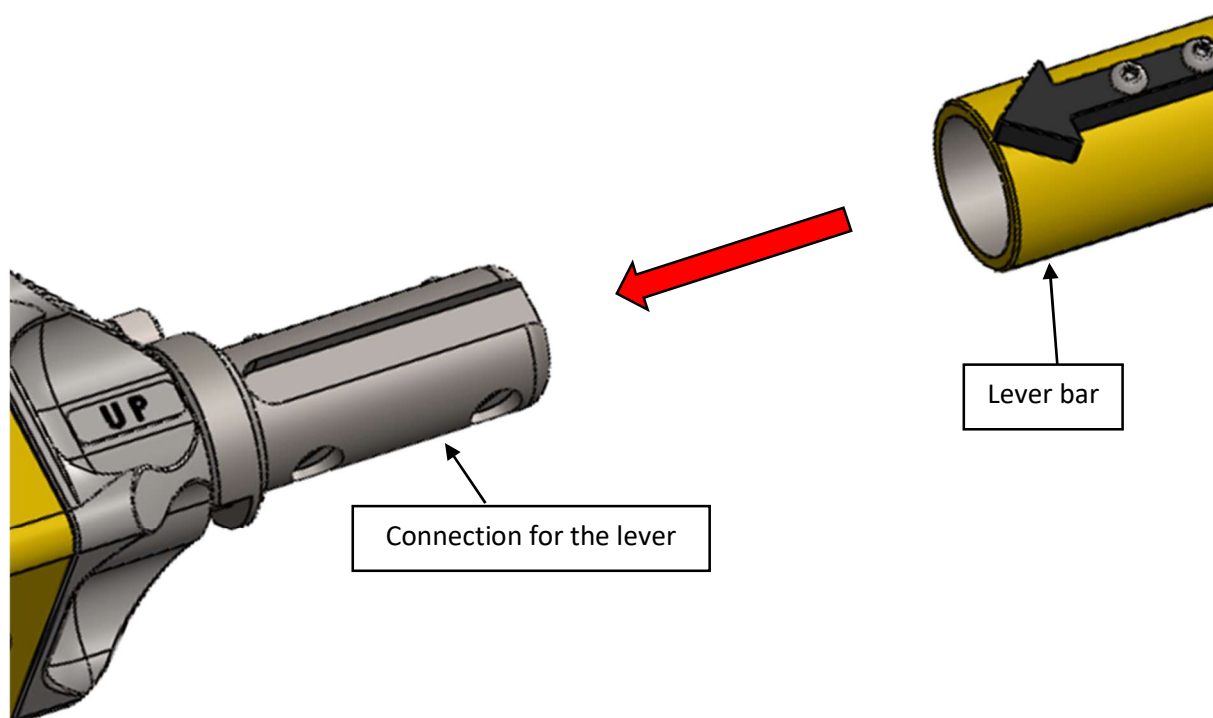

Written by | Date: MATEUS FREITAS | 24/OUT/24

Approved by | Date: PHIL XAVIER | 25/OUT/24

Updated by | Date: MATEUS FREITAS | 04/DEC/24

Approved by | Date: PHIL XAVIER | 04/DEC/24

5.2 LEVERAGE OPERATION

Before starting the operation, make sure the tires are calibrated in accordance with the limitations section of this manual. Also, ensure that the equipment is completely unlevered, with the arm perpendicular to the ground. Make sure that all the aircraft doors are closed and locked.

For moving the HARDMOB 135 close to the aircraft, use the lever bars to push the equipment close to the coupling point on the helicopter skid. The levering mechanisms must always be facing the nose of the aircraft.

With the equipment close to the attachment point, and with the lever tilted backwards, hold the equipment, one hand on the handle and the other on the tire, and push the equipment towards the skid as shown below. Make sure the tire is in contact with the ground at all times, in order to mitigate possible impacts of the equipment on the ski, and to facilitate the coupling process.

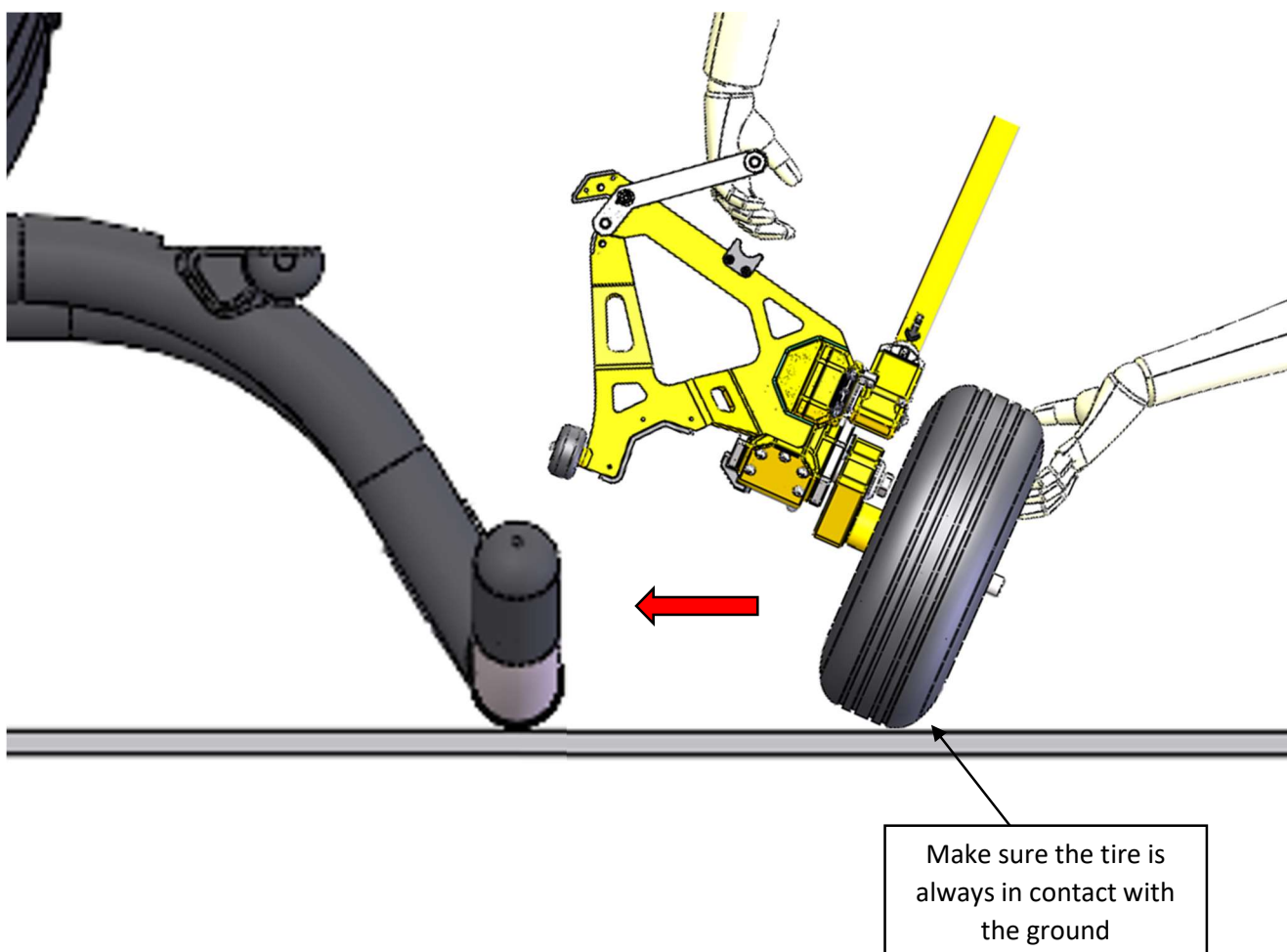

Written by | Date: MATEUS FREITAS | 24/OUT/24

Approved by | Date: PHIL XAVIER | 25/OUT/24

Updated by | Date: MATEUS FREITAS | 04/DEC/24

Approved by | Date: PHIL XAVIER | 04/DEC/24

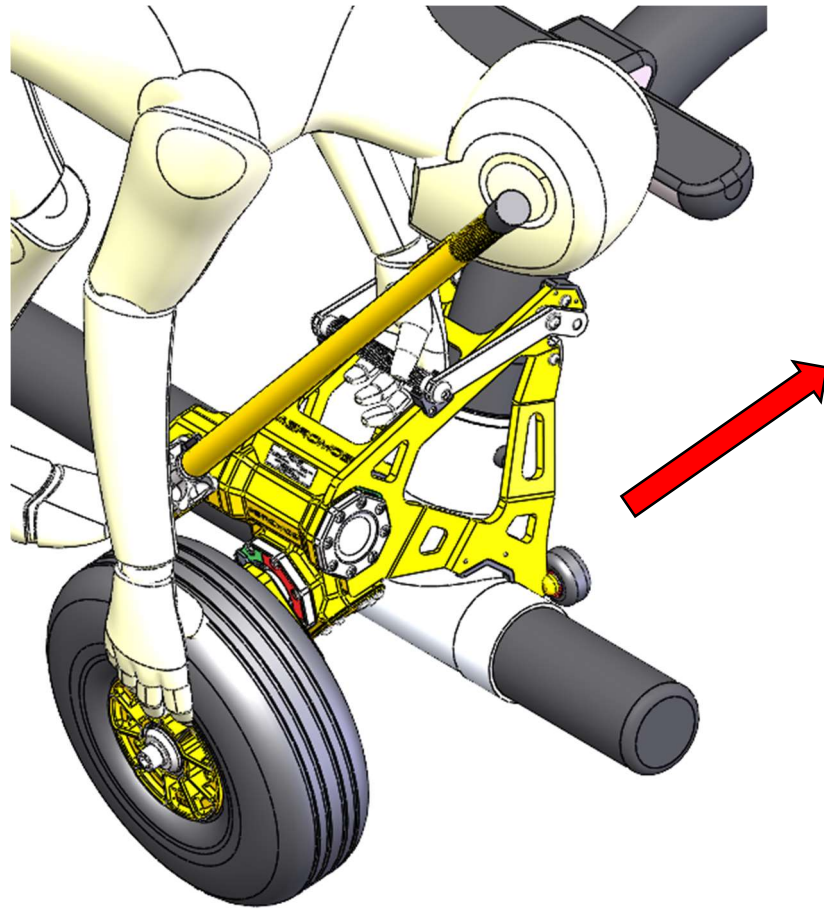

Make sure the clamping channels of the HARDMOB 135 are perfectly aligned with the aircraft pins located on the skid's crosstube, as shown below.

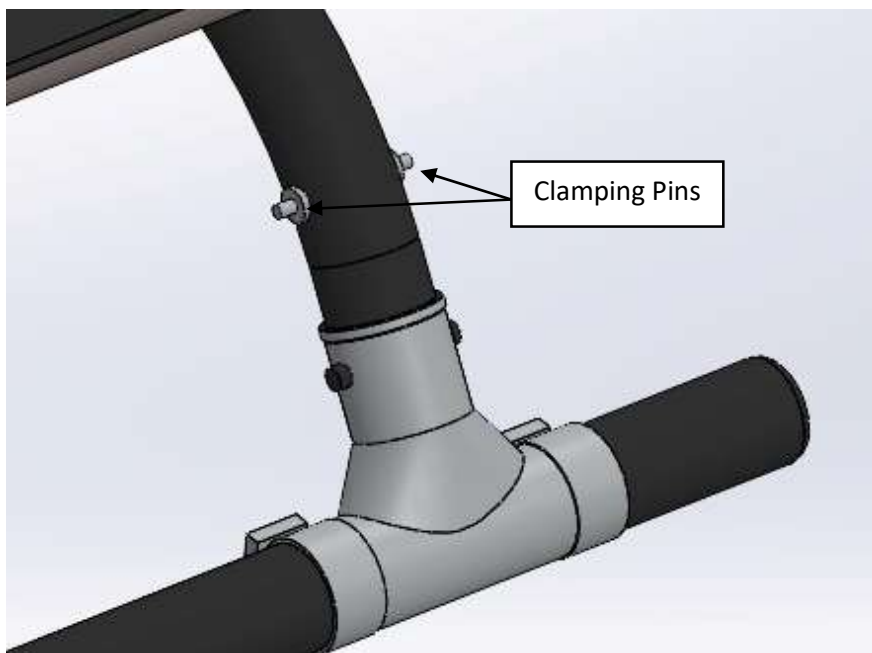

Written by | Date: MATEUS FREITAS | 24/OUT/24

Approved by | Date: PHIL XAVIER | 25/OUT/24

Updated by | Date: MATEUS FREITAS | 04/DEC/24

Approved by | Date: PHIL XAVIER | 04/DEC/24

With the clamping channels perfectly attached to the 2 skid clamping pins, push the top handle downwards, locking the coupling mechanism in place.

Then, bring the lever forward. Twist the lever bar until the indicator is aligned with the “UP” position, as indicated below.

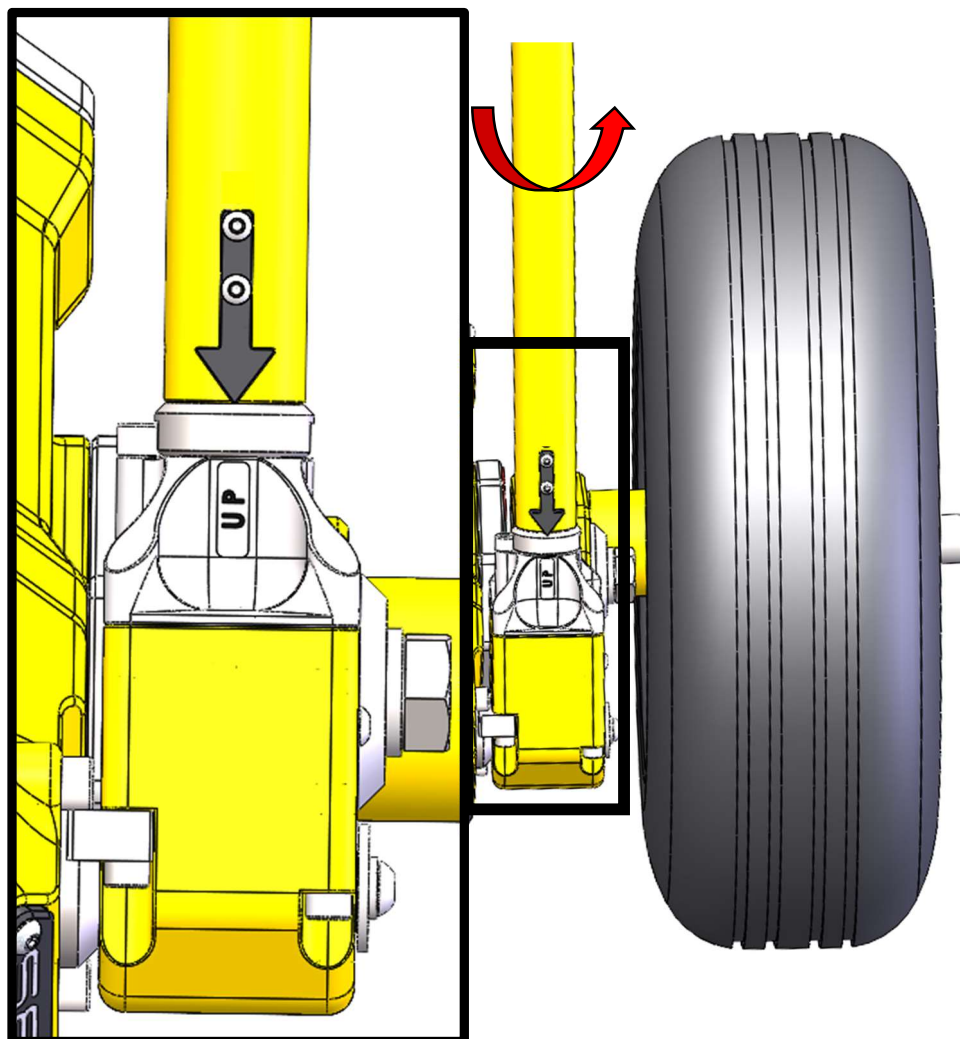

Stand next to the aircraft and perform the leverage procedure as shown below. To raise the aircraft, push the lever DOWN, with the lever bar always aligned the nose of the aircraft. Make sure your body is also aligned towards the nose of the helicopter, to ensure a safe and ergonomic operation.

Written by | Date: MATEUS FREITAS | 24/OUT/24

Approved by | Date: PHIL XAVIER | 25/OUT/24

Updated by | Date: MATEUS FREITAS | 04/DEC/24

Approved by | Date: PHIL XAVIER | 04/DEC/24

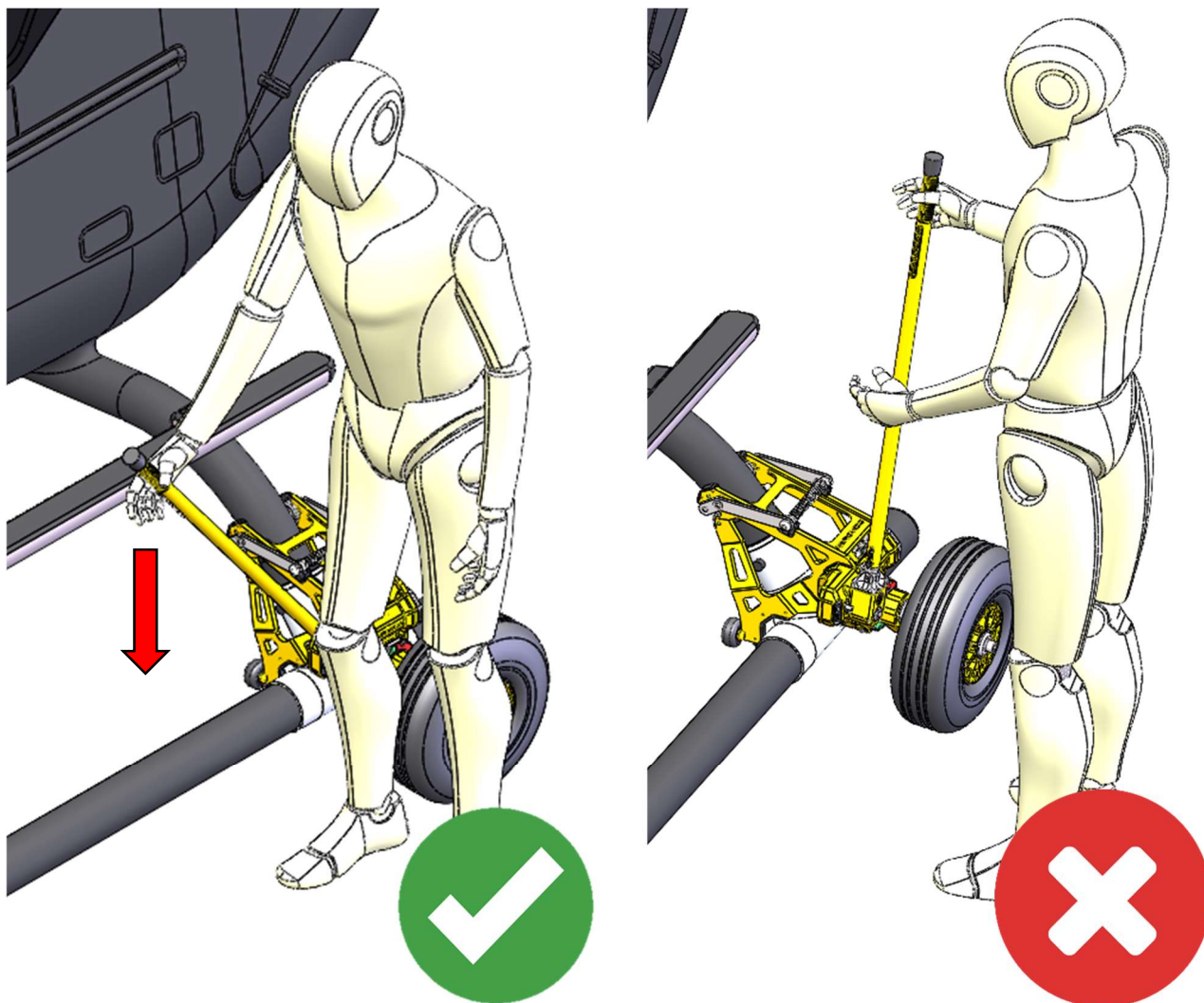

Lever the bar in a downwards motion until the indicator on the body of the HARDMOB 135 points upwards, reaching the end of the GREEN stroke area. At this point, the aircraft will be fully suspended. DO NOT continue levering past this point.

The cursor must NEVER reach the RED area. During leverage and de-leverage, the indicator must always run along the GREEN area of the stroke. Operating the HARDMOB 135 with the cursor in the RED area does not pose a risk to the operation or structural integrity of the equipment, but it does make the operation cumbersome and non-ergonomic. Use in that configuration is neither intended nor approved by AEROMOB.

Written by Date: MATEUS FREITAS 24/OUT/24	Approved by Date: PHIL XAVIER 25/OUT/24
Updated by Date: MATEUS FREITAS 04/DEC/24	Approved by Date: PHIL XAVIER 04/DEC/24

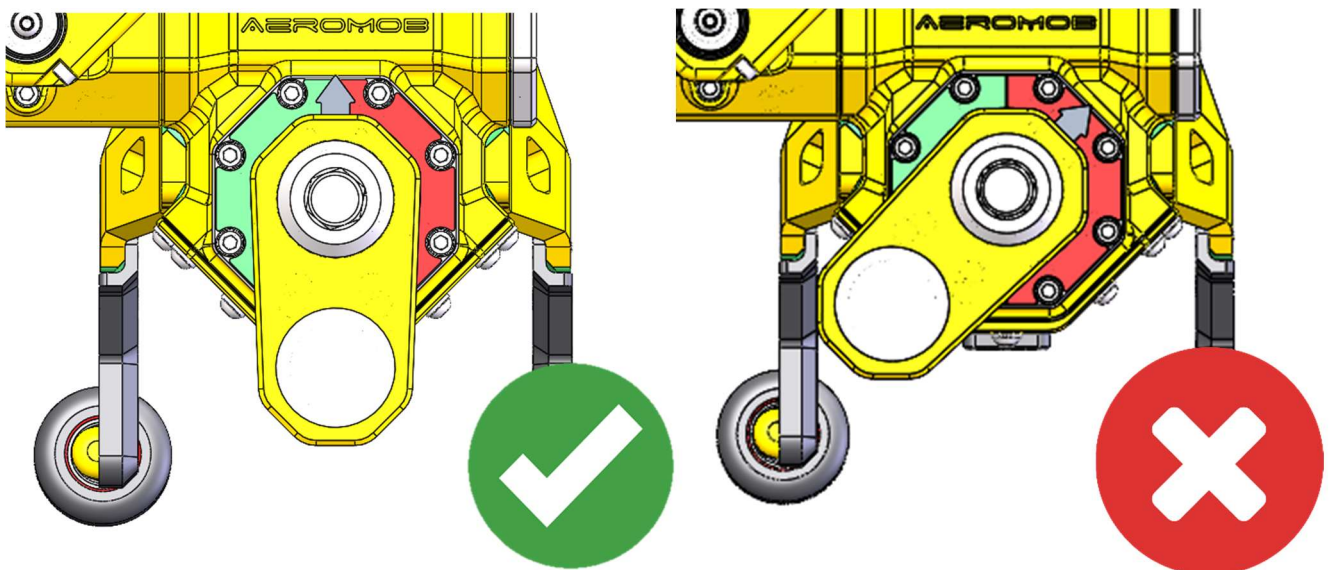

After raising one side of the aircraft, a second operator should be positioned near the tail of the helicopter to prevent the helicopter from tipping-back. The operator positioned close to the tail must hold on only to points approved for this purpose by the aircraft manufacturer.

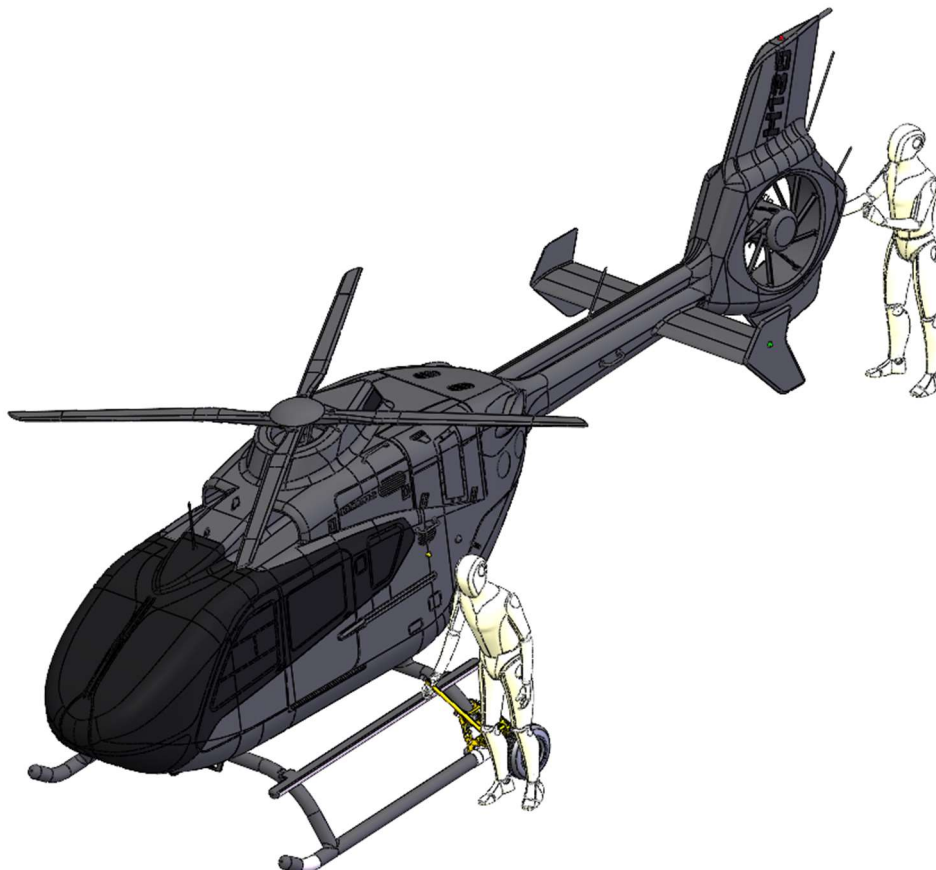

Tilt the lever backwards and repeat the 5.2 procedure for the other side of the aircraft.

Written by Date: MATEUS FREITAS 24/OUT/24	Approved by Date: PHIL XAVIER 25/OUT/24
Updated by Date: MATEUS FREITAS 04/DEC/24	Approved by Date: PHIL XAVIER 04/DEC/24

WARNING

WHEN LEVERAGING AND DE-LEVERAGING, MAKE SURE THAT NO OBJECTS OR BODY PARTS IS UNDER THE SKID. DOUBLE ATTENTION IS DUE TO THE OPERATORS' FEET, TO MAKE SURE THEY ARE NEVER UNDER THE SKID.

5.3 HANDLING

There are two options for moving the aircraft: manually pushing the suspended aircraft, or using a tow bar. Before starting the handling procedure, double-check that all the aircraft doors are properly closed and locked.

For manual handling, it is necessary for one operator to hold the tail so that the aircraft is suspended, and two other operators to push the aircraft, as shown below. The operators pushing the aircraft must hold on only to the skid's cross-tube and footstep, and never apply pressure on the fuselage.

INTENTIONALLY LEFT BLANK

Written by Date: MATEUS FREITAS 24/OUT/24	Approved by Date: PHIL XAVIER 25/OUT/24
Updated by Date: MATEUS FREITAS 04/DEC/24	Approved by Date: PHIL XAVIER 04/DEC/24



To tow the aircraft with a motorized vehicle, it is recommended to use AEROMOB's CARTMOB (PN AM-CRT-K02) tow bar or E-MOB 1.0 (PN AM-EMOB1.0-K01). For more information, see the equipment's respective User Manual.

5.4 DE-LEVERING

After moving the aircraft manually or using a motorized vehicle attached to the CARTMOB or E-MOB 1.0, the front of the skid must be lowered until its front touches the ground gently.

Before deleveraging, make sure that there is an operator positioned near the tail of the aircraft, preventing it from tipping-back, until the first side of the skid has been fully disengaged.

Written by Date: MATEUS FREITAS 24/OUT/24	Approved by Date: PHIL XAVIER 25/OUT/24
Updated by Date: MATEUS FREITAS 04/DEC/24	Approved by Date: PHIL XAVIER 04/DEC/24

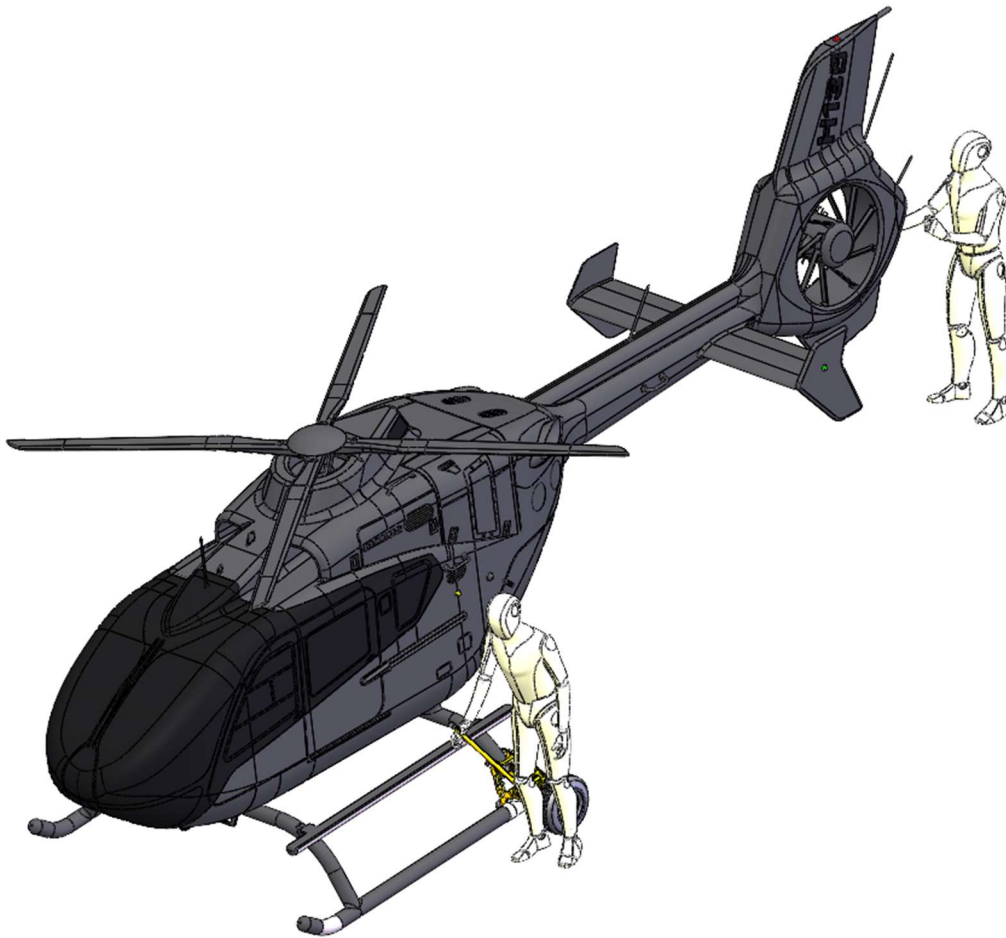

To de-lever the HARDMOB 135, twist the lever to the “DOWN” position, as indicated on the equipment. Operate the lever bar by pulling it UP, lowering the aircraft until the indicator on the body of the HARDMOB 135 reaches the lower limit on the GREEN stroke, as shown below.

INTENTIONALLY LEFT BLANK

Written by | Date: MATEUS FREITAS | 24/OUT/24

Approved by | Date: PHIL XAVIER | 25/OUT/24

Updated by | Date: MATEUS FREITAS | 04/DEC/24

Approved by | Date: PHIL XAVIER | 04/DEC/24

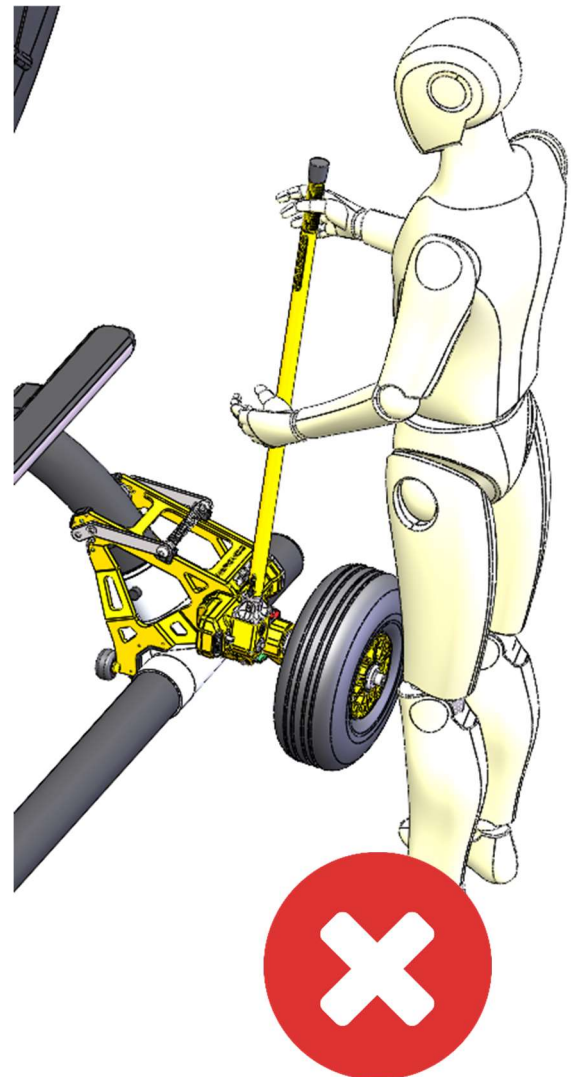
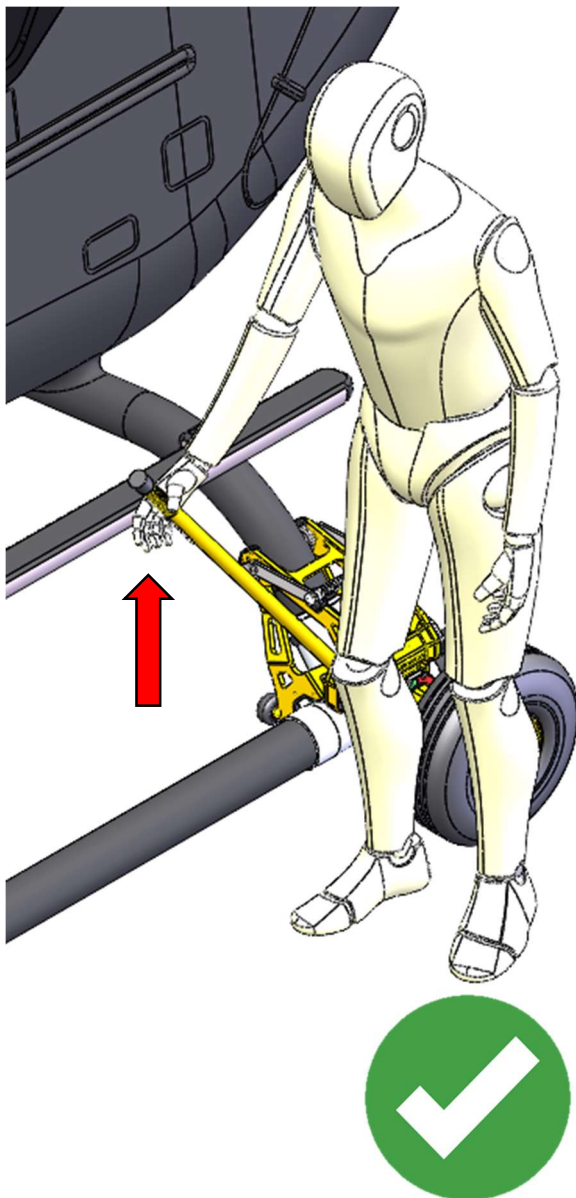

5.5 DECOUPLING THE EQUIPAMENT

With the equipment's lever bar tilted backwards, pull the HARDMOB 135's locking handle upwards and unhook the equipment, holding it by the handle and the tire. Keep the tire in contact with the ground at all times to facilitate the operation.

Written by | Date: MATEUS FREITAS | 24/OUT/24

Approved by | Date: PHIL XAVIER | 25/OUT/24

Updated by | Date: MATEUS FREITAS | 04/DEC/24

Approved by | Date: PHIL XAVIER | 04/DEC/24

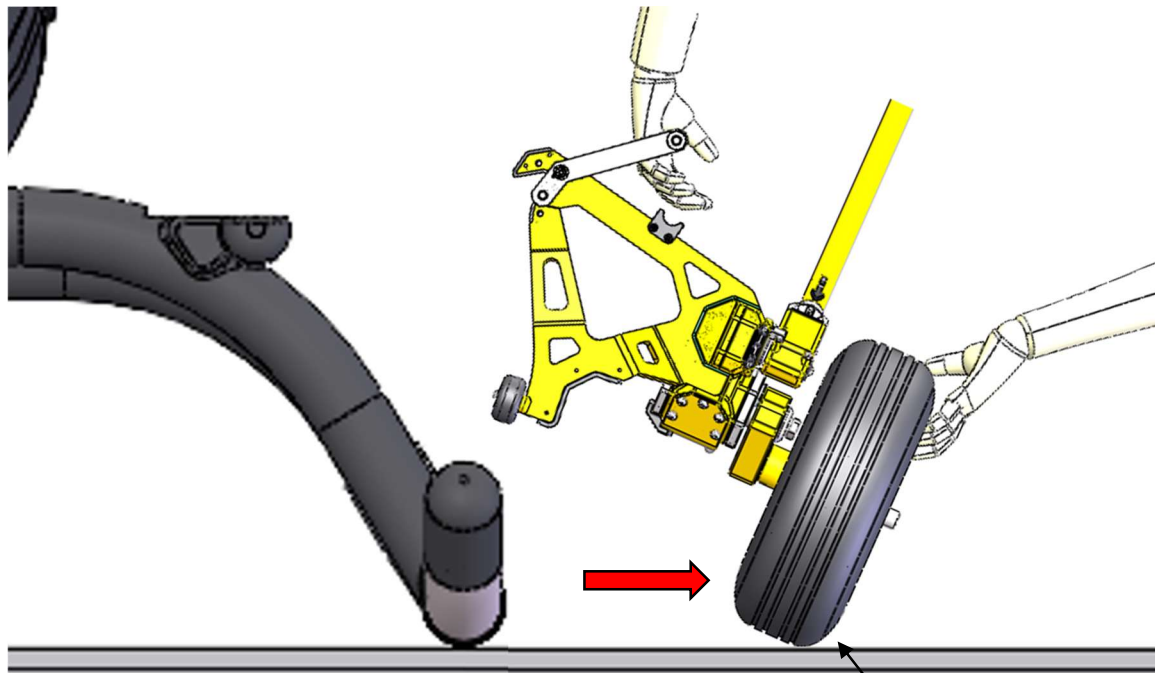

Make sure the tire is always in contact with the ground

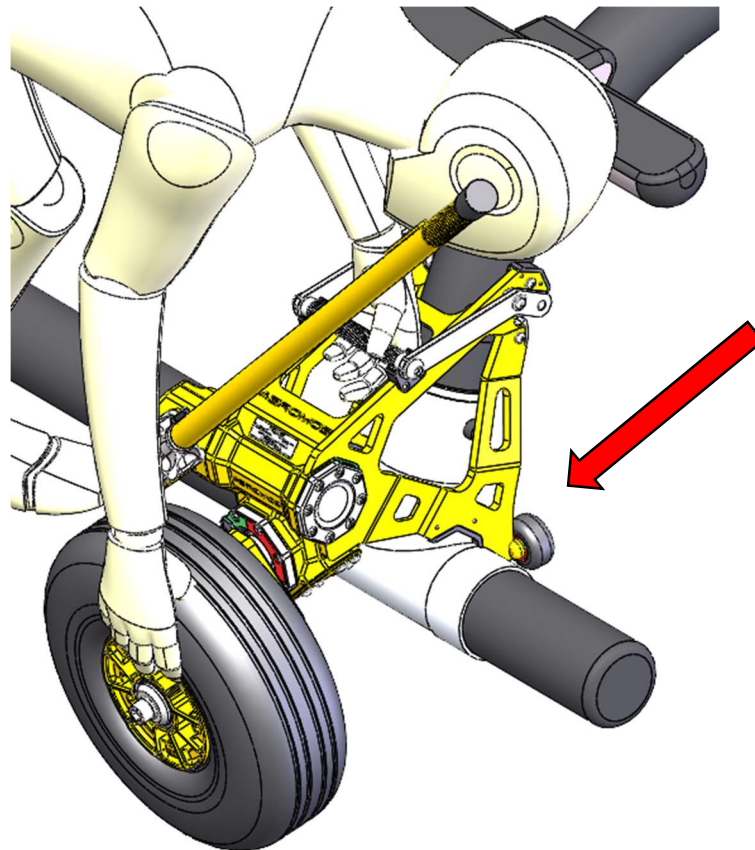

Repeat steps 5.4 and 5.5 on the other side of the aircraft.

Written by Date: MATEUS FREITAS 24/OUT/24	Approved by Date: PHIL XAVIER 25/OUT/24
Updated by Date: MATEUS FREITAS 04/DEC/24	Approved by Date: PHIL XAVIER 04/DEC/24

6 STORING

To store the HARDMOB 135, keep the lever bar attached to the equipment. The equipment may be kept coupled to the aircraft, as long as it is completely unlevered, for easy and efficient use; the equipment may also be stored inside the hangar. Make sure that its positioning does not create an obstacle to the movement of people or aircrafts. To ensure the preservation of equipment tires, keep the equipment sheltered from the weather, the sun and the environment. Otherwise, the tire will dry out and present small cracks scattered around, impairing the operation.

Keep the equipment out of the reach of children. To take the equipment on board, simply disconnect the lever bar and transport it normally.

7 PROHIBITIONS

- **NEVER** authorize anyone to use this equipment without first reading this instruction manual;
- **NEVER** operate the equipment with a non-calibrated tire. Operating with a flat tire generates continuous and deep cracks in its surface, permanently damaging the tire.
- **DO NOT** use this equipment with people or luggage aboard the aircraft;
- **DO NOT** use this equipment on uneven terrain that causes severe shaking or jolting, as this may pose a risk of damage to the aircraft and/or operators near the aircraft;
- **DO NOT** use the equipment on other helicopter models, above the approved weight, or for unapproved functions.
- **NEVER** open or unlock the doors of the aircraft while it is being leveraged, already suspended, moving or during de-leveraging;
- **NEVER** operate the aircraft while the HARDMOB 135 is attached;
- **NEVER** use this equipment if any part, protection, component or identification plate is missing or damaged;
- **NEVER** use the equipment with any part or component that is not part of this set and/or has not been supplied by the manufacturer;
- **DO NOT** allow this equipment to be operated or handled by children;
- The cursor must **NEVER** advance into the RED area. During leveraging and de-leveraging, the indicator must always run along the GREEN area of the stroke. Operating the HARDMOB 135 with the cursor on the RED area does not pose a risk to the operation or structural integrity of the equipment, but it does make the operation more cumbersome and non-ergonomic. Use in this configuration is neither intended nor approved by AEROMOB.

Written by Date: MATEUS FREITAS 24/OUT/24	Approved by Date: PHIL XAVIER 25/OUT/24
Updated by Date: MATEUS FREITAS 04/DEC/24	Approved by Date: PHIL XAVIER 04/DEC/24

- **DO NOT** leverage the equipment with the lever selector in the “DOWN” option;
- **DO NOT** de-lever the equipment with the lever selector in the “UP” option;
- **DO NOT** operate the equipment under any circumstances if any object, foot, hand or other body part is under the aircraft skid;
- **DO NOT** leave the equipment exposed to the weather, the sun or the environment for long periods of time to ensure the longevity of the tires;

8 PRODUCT DOCUMENTS

8.1 FLIGHT MANUAL SUPPLEMENT (FMS)

The Flight Manual Supplement (FMS), sent printed with the equipment and available for digital consultation, should be inserted into the flight manual (POH), in the SUPPLEMENTS section, for quick access of basic information relating to this equipment. To access the updated version of the Flight Manual Supplement (FMS), go to: www.aeromob-industry.com/support-am-hdm-135-k01 or just scan the QR CODE available in this Manual.

8.2 USER MANUAL

This document is the User Manual. It is mandatory reading before operating this equipment. To access the updated version of the User Manual, go to: www.aeromob-industry.com/support-am-hdm-135-k01 or just scan the QR CODE available in this Manual.

8.3 MAINTENANCE PROCEDURES

The overhaul plan and any necessary maintenance procedures must be carried out in accordance with the maintenance manual, document part number MM-AM-HDM-135-K01. To access the updated version of the Maintenance Manual, go to: www.aeromob-industry.com/support-am-hdm-135-k01 or just scan the QR CODE available in this Manual.

8.4 SPARE PARTS

The Illustrated Parts Catalog - IPC is the official reference document for ordering spare parts, part number IPC-AM-HDM-135-K01. To access the updated version of the Illustrated Parts Catalog, go to: www.aeromob-industry.com/support-am-hdm-135-k01 or just scan the QR CODE available in this Manual.

Written by Date: MATEUS FREITAS 24/OUT/24	Approved by Date: PHIL XAVIER 25/OUT/24
Updated by Date: MATEUS FREITAS 04/DEC/24	Approved by Date: PHIL XAVIER 04/DEC/24

8.5 WARRANTY

Your equipment has a 1-year warranty and, if necessary, can be requested directly from AEROMOB via the link: www.aeromob-industry.com/support-am-hdm-135-k01 or by scanning the QR CODE available in this Manual.

8.6 SUPPORT

If you have any questions about how to use the equipment, please contact our support team. Do not use the equipment if you have any doubts about its operation. If you notice any faults with the equipment, if components are missing, or in any other case where support is required, please contact us via the website, which can be accessed via the link: www.aeromob-industry.com/support-am-hdm-135-k01 or by scanning the QR CODE available in this Manual.

INTENTIONALLY LEFT BLANK

Written by Date: MATEUS FREITAS 24/OUT/24	Approved by Date: PHIL XAVIER 25/OUT/24
Updated by Date: MATEUS FREITAS 04/DEC/24	Approved by Date: PHIL XAVIER 04/DEC/24

9 ACCESS TO ALL UPDATED DOCUMENTATION

Below is a list of files and documents available to the customer of this equipment and the QR CODE for access to the always up-to-date version:

(PN FMS-AM-HDM-135-K01) FLIGHT MANUAL SUPPLEMENT

(PN UM-AM-HDM-135-K01) USER MANUAL

(PN MM-AM-HDM-135-K01) MAINTENANCE MANUAL

(PN IPC-AM-HDM-135-K01) ILLUSTRATED PARTS CATALOG



www.aeromob-industry.com/support-am-hdm-135-k01

Written by Date: MATEUS FREITAS 24/OUT/24	Approved by Date: PHIL XAVIER 25/OUT/24
Updated by Date: MATEUS FREITAS 04/DEC/24	Approved by Date: PHIL XAVIER 04/DEC/24