

MAINTENANCE MANUAL

HARDMOB 145

PN: AM-HDM-145-K01

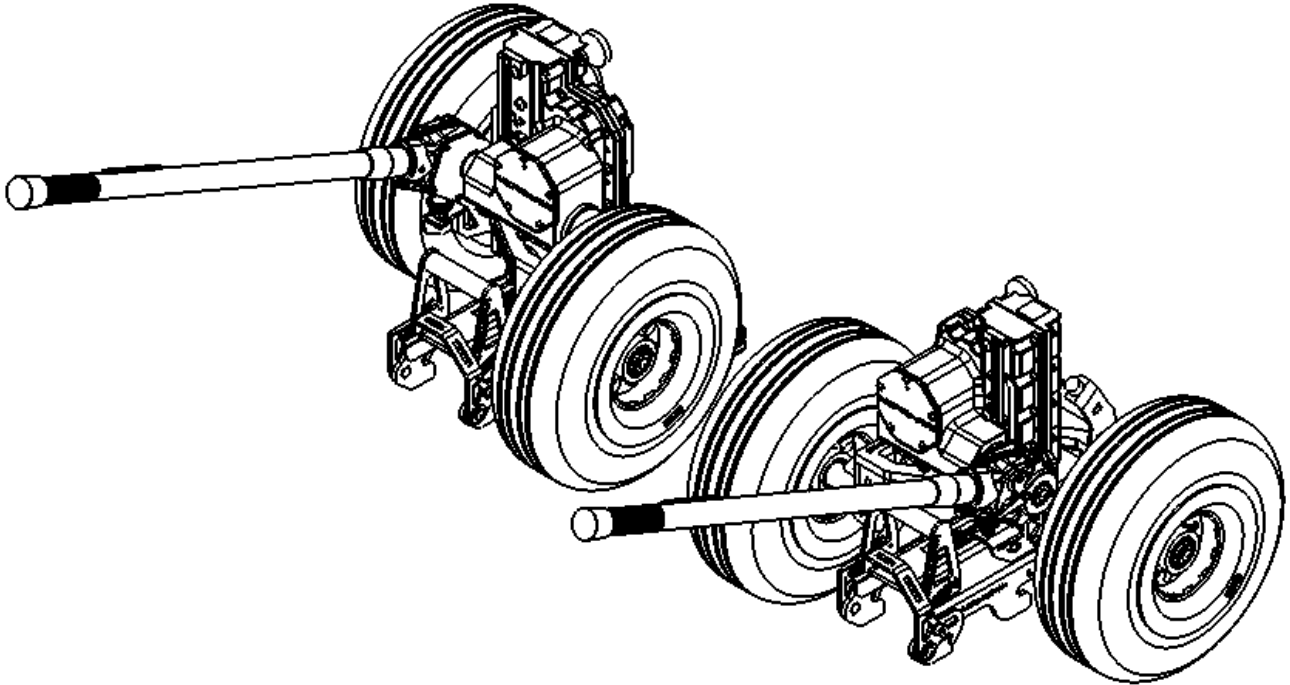

Aeromob Equipamentos Aeronáuticos Ltda

CNPJ: 40.061.679/0001-43

Address: Rua Carlos Willy Boehm, 990 - Costa e Silva

Zip Code: 89218-325 - Joinville - SC

Phone: +55 (47) 4101-2724 | 9 9937-9077

Website: www.aeromob-industry.com

This document is protected by copyright. Total or partial copying of the text, images or tables without authorization from AEROMOB is expressly prohibited, subjecting the offender to applicable civil and criminal proceedings, without prejudice to financial liability for losses and damages caused.

REVISION

Revision N°	Date
01	26/03/2024

To access the updated version of this document, point your device at the QR CODE below.



www.aeromob.com.br/support-am-hdm-145d-k01

INTRODUCTION

This Maintenance Manual must be used in conjunction with the IPC (Illustrated Parts Catalog) part number **IPC AM-HDM-145-K01**, to maintain the equipment in perfect conditions of use, providing safety and quality in the application.

The procedures determined in this document aim to ensure the correct execution of maintenance actions applicable to this equipment, to guarantee the safety and efficiency of maintenance and operation of the equipment.

Keeping maintenance up to date will prevent accidents and prevent the product from being stopped due to failures. Cleaning, lubrication, and inspections are basic conditions for proper operation.

NOTE: This Manual provides for execution on the right side and should be used as a reference to perform work on the left side when appropriate.

NOTE 2: For maintenance actions not recommended in this document, do not run without prior Aeromob support for more information: www.aeromob-Industry.com/support-am-ldr-145-K01.

LIST OF ABBREVIATIONS

Throughout the manual you will find references such as:

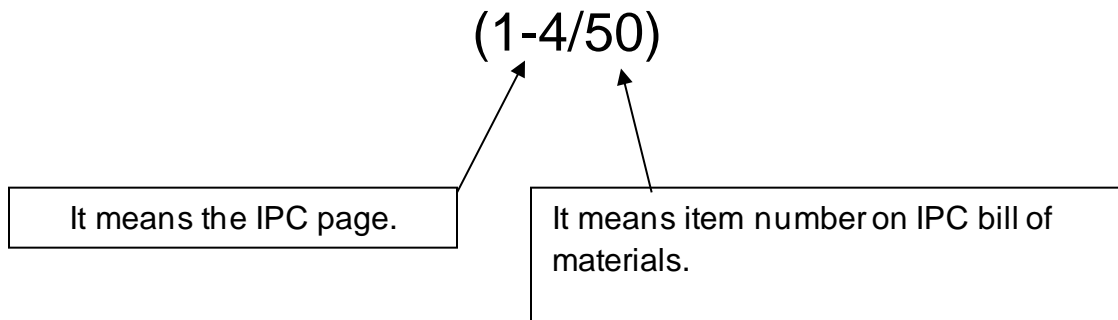

BASIC EQUIPMENT DIMENSIONS

This equipment has the following dimensions:

Tires diameter: 352 mm

Weight: 50 Kg

Tires pressure: 105 PSI

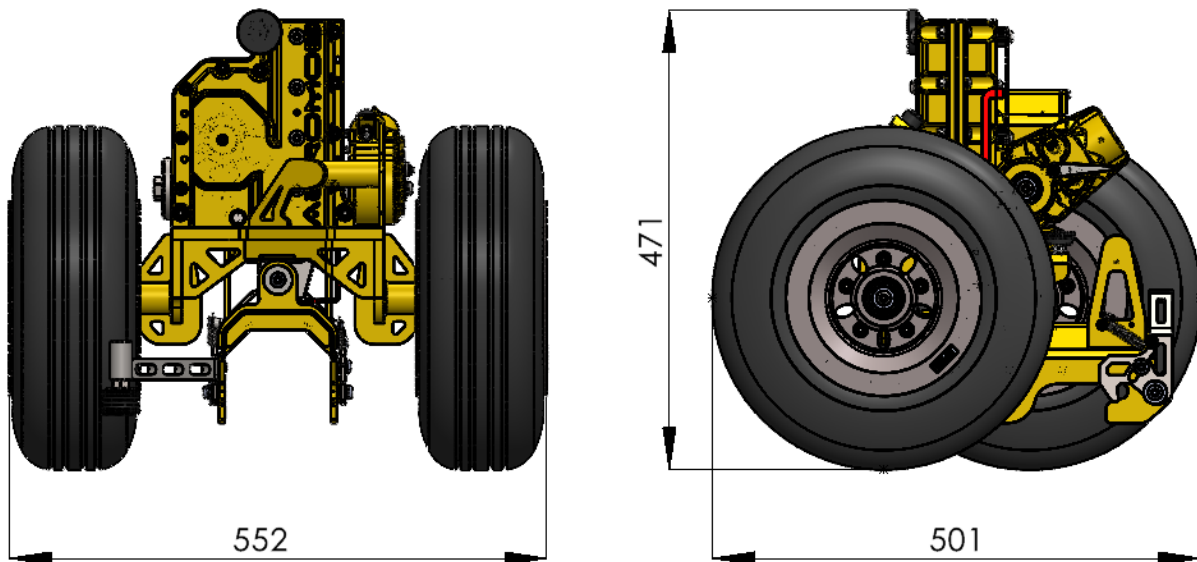

SUMMARY

INSPECTIONS CHECKLIST.....	10
SUBPART 03 – ROUTINE MAINTENANCE (CLEANING, CALIBRATION E LUBRIFICATION).....	11
Equipment Cleaning MM AM-HDM-145-K01/3-1	12
Tire Calibration MM AM-HDM-145-K01/3-2	13
Lubrication MM AM-HDM-145-K01/3-3	14
SUBPART 04 – DISASSEMBLY AND ASSEMBLY	15
Disassembly / Assembly – Separation of Components MM AM-HDM-145-K01/4-0.....	16
Disassembly / Assembly – Body MM AM-HDM-145-K01/4-1	27
Disassembly / Assembly – Base MM AM-HDM-145-K01/4-2	42
Disassembly / Assembly – Wheel MM AM-HDM-145-K01/4-3	44
Disassembly / Assembly – Lever bar MM AM-HDM-145-K01/4-4	48
Disassembly / Assembly – Ratchet handle MM AM-HDM-145-K01/4-5	49
Disassembly / Assembly – Grab MM AM-HDM-145-K01/4-6	51
Disassembly / Assembly – Worm Shaft MM AM-HDM-145-K01/4-7	53
SUBPART 05 – TESTING AND CALIBRATION	
No items applicable to this equipment	

SUBPART 06 – INSPECTIONS

No items applicable to this equipment

SUBPART 07 - TROUBLESHOOTING.....55

Failure List.....56

Lift System Failure.....57

Flat tire.....59

SUBPART 08 – INSPECTIONS

No items applicable to this equipment

INSPECTIONS LIST

DESCRIPTION	CODE	FREQUENCY
Full lubrication	MM AM-HDM-145-K01/3-1	3 years / 1000 cycles
Tire replacement	MM AM-HDM-145-K01/3-6	On Condition

The other components are ON-CONDITION and must be in perfect condition. Only the use of equipment is permitted if the set is complete and in perfect working order. It is expressly prohibited and dangerous to use the equipment with any part, information plate or component missing. If it is necessary to replace any item or component, contact Aeromob. The equipment must contain all items declared in the IPC so that the equipment is fit and safe for operation.

Tires must be inflated to 105 PSI. It is mandatory that all 4 tires are calibrated before using the equipment. If the ambient temperature varies by more than 10 °C from the day of calibration until the moment the equipment is used, the tires must be recalibrated before use.

Calibration outside of specifications may cause risk of bodily injury and/or damage to equipment.

If the tires are dry or cracked, they must be replaced before the next use. Consult Aeromob for the supply of tires and tubes.

Keeping the equipment clean, in addition to making it more beautiful, is very important for your safety. Dirt can hide abnormalities that could potentially cause failure. During cleaning, it is necessary to check for the presence of cracks, gaps, deformations, noise, misalignment and any other wear or irregular characteristics.

SUBPART 03

ROUTINE PROCEDURES

Equipment Cleaning

MM AM-HDM-145-K01/3-1

A. Applicable documents

N/A

B. Specials Tools

N/A

C. Materials

- a. Kerosene e clean cotton waste.

D. Routine Spare Parts

N/A

E. Work Setup

- a. Put the equipment in a clean environment with good lighting.

F. Cleaning Procedure

- a. Apply the cotton waste with kerosene to all metal parts of the equipment to remove dirt. Visually inspect the parts, evaluating the presence of cracks, deformations, noise or inappropriate behavior of the product.

Tire Calibration

MM AM-HDM-145-K01/3-2

A. Applicable Documents

N/A

B. Specials Tools

- a. Air pressure gauge and air pump.

C. Materials

N/A

D. Routine Spare Parts

N/A

E. Work Setup

N/A

F. Procedure

- a. Apply air pressure gauge and make sure your tire pressure is 105 PSI. If different, adjust the pressure to the prescribed value.

Lubrication

MM AM-HDM-145-K01/3-3

A. Applicable Documents

N/A

B. Specials Tools

- a. Grease pump.

C. Materials

- a. Lubricant AM-LUB-BI01 and grease AM-LUB-GX12, both supplied by Aeromob.

D. Routine Spare Parts

N/A

E. Work Setup

N/A

F. Procedure

- a. Use the grease pump to apply the lubricant to the two grease nipples on the equipment.

SUBPART 04

DISASSEMBLY AND ASSEMBLY

Disassembly / Assembly – SEPARATION OF COMPONENTS

MM AM-HDM-145-K01/4-0

A. Applicable Documents

- a. IPC AM-HDM-145D-K01.

B. Specials Tools

- a. Hot air gun 1800 W.
- b. Ratchet Handle puller tool FM-HDM-145-F01.

C. Materials

N/A

D. Routine Spare Parts

N/A

E. Work Setup

N/A

F. Disassembly procedure

- a. With the equipment positioned and locked on the aircraft skid, apply a heat gun to the screw (1-4/21) for 5 minutes, being careful not to heat the tire or the equipment body. See Figure 1.

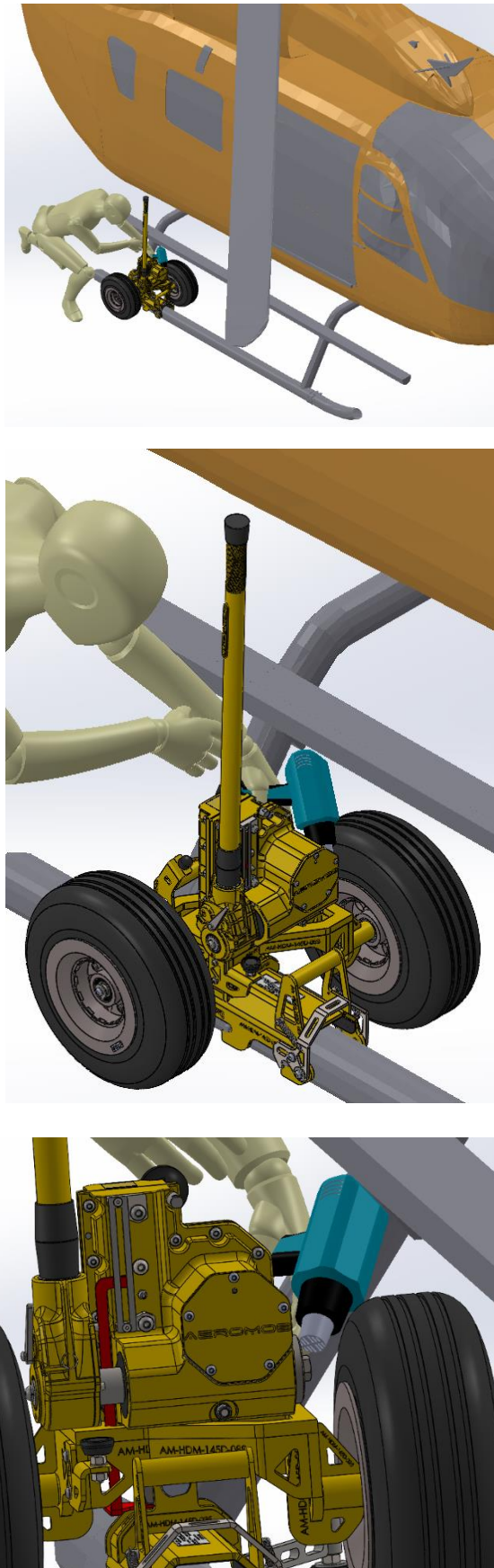

Figure 1

- b. Put the ratchet handle selector lever (5-3/8) in the UP position. Activate the lever bar until the level marker is at least 10 mm from the lower limit of the scale, see Figure 2.

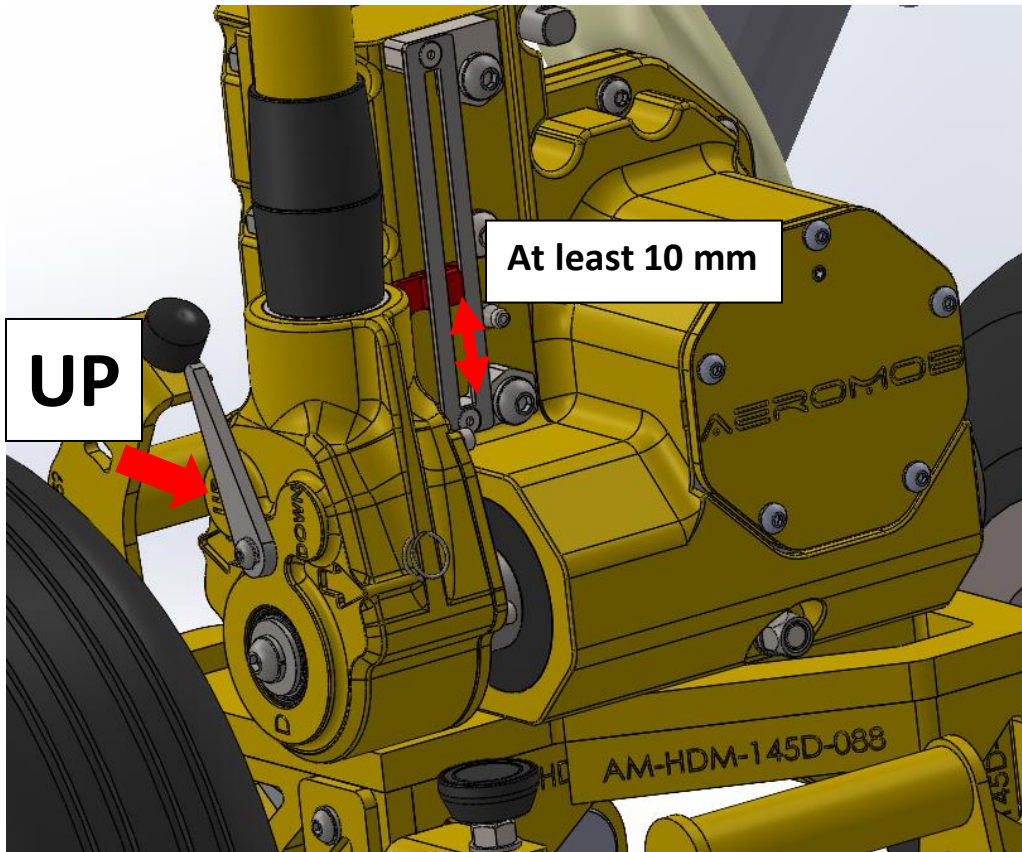

Figure 2

- c. Now put the ratchet handle selector lever (5-3/8) in the DOWN position.
- d. One operator must lock the screw (1-4/21) with a wrench while another operator operates the lever bar until the screw is loose. See Figure 3.

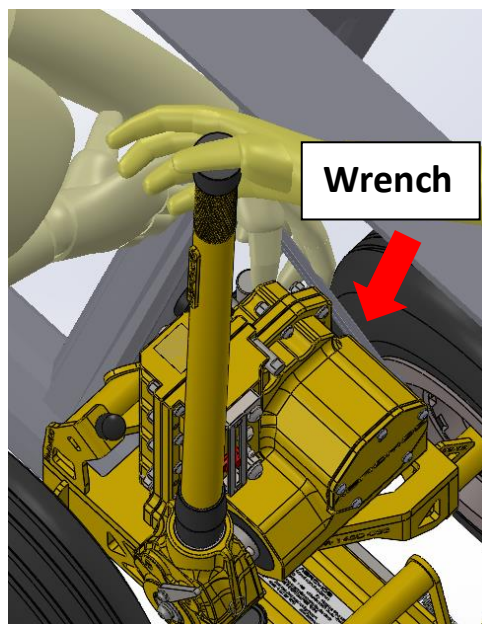
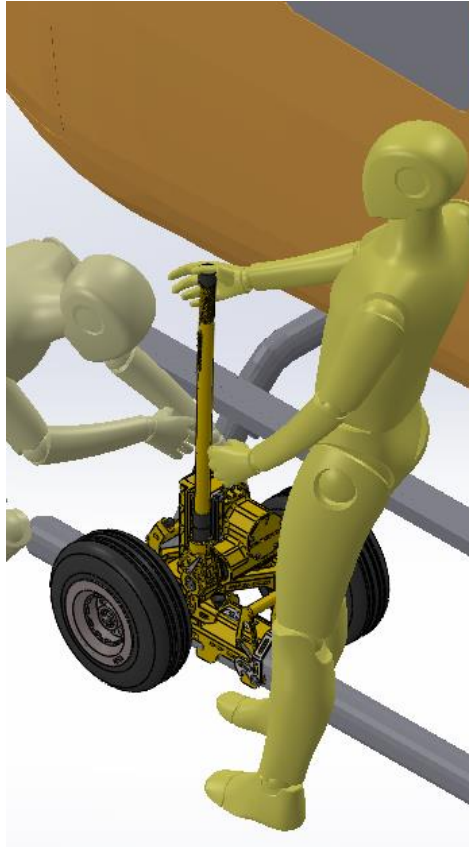

Figure 3

- e. Remove the equipment from the aircraft and take it to the repair workshop.
- f. Pull the lever bar to remove it from the equipment.
- g. Removes the drop stop (1-4/19) and special nut (1-4/23).
- h. Position the equipment on a clean, rubberized bench, with the wheels facing up, using support FM-HDM-145-M02.
- i. Use the heat gun (1800 W for 2 minutes) to remove the thread lock glue from the screws (2-3/16).
- j. Remove the screw (2-3/16) and remove the wheel. Repeat Procedure “d” and remove the other wheel.
- k. Apply the heat gun (1800 W) to the screw (6-3/18) for 2 minutes to remove the thread lock glue. Remove the screw.
- l. Remove the pin (6-3/7) and remove the grab from the equipment.
- m. Loosen the screws (1-4/51) and remove the arrow (1-4/14).
- n. Loosen the screws (2-3/14) and (2-3/13). Remove the equipment base.
- o. To remove the ratchet handle, pay attention to the direction of the thread: if the marking is “D” it is right-hand thread, if the marking is “E” it is left-hand thread. Use a heat gun for 2 minutes on the screw (1-4/57) to remove the thread lock glue. Remove the screw and washer belonging to the assembly.
- p. Use the FM-HDM-145-F01 handle puller and remove it from the equipment.
- q. The disassembly of the parts for each component is presented in later sections. To separate the components, see the chapters MM AM-HDM-145-K01/4-1, AM-HDM-145-K01/4-2, AM-HDM-145-K01/4-3, AM-HDM-145-K01/4-4, AM-HDM-145-K01/4-5, AM-HDM-145-K01/4-6 e AM-HDM-145-K01/4-7.

G. Assembly procedure

- a. The assembly of the parts for each component is presented in subsequent sections. To assemble each subassembly, see section G of chapters MM AM-HDM-145-K01/4-1, AM-HDM-145-K01/4-2, AM-HDM-145-K01/4-3, AM-HDM-145-K01/4-4, AM-HDM-145-K01/4-5, AM-HDM-145-K01/4-6 e AM-HDM-145-K01/4-7.
- b. With the block assembled according to MM AM-HDM-145-K01, place it upside down, tilt the arrow (1-4/14) towards the cover (1-4/8) as shown in Figure 4. Position the tip of the arrow in the pit, as shown in the top view of Figure 5. Carefully move the part into the mentioned pit and rotate it to a vertical position. Install screws (1-4/51).

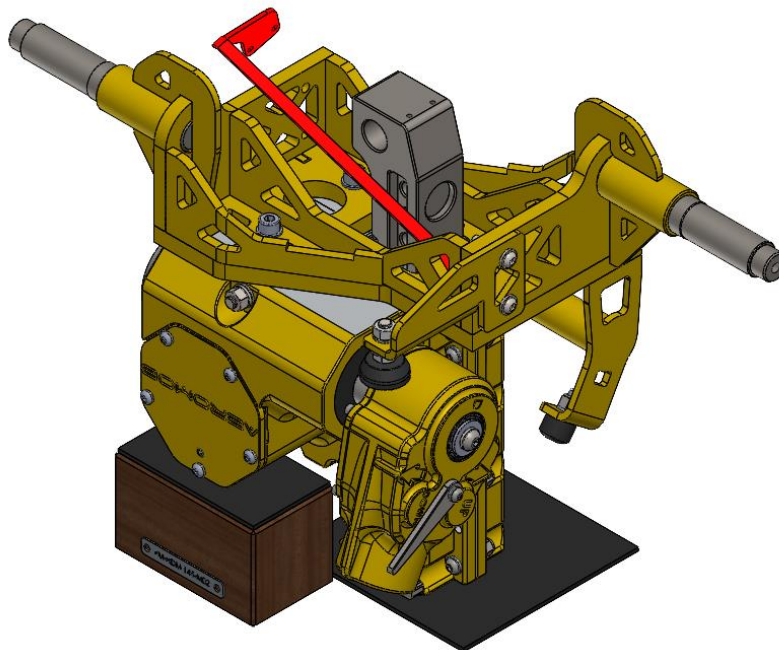

Figure 4

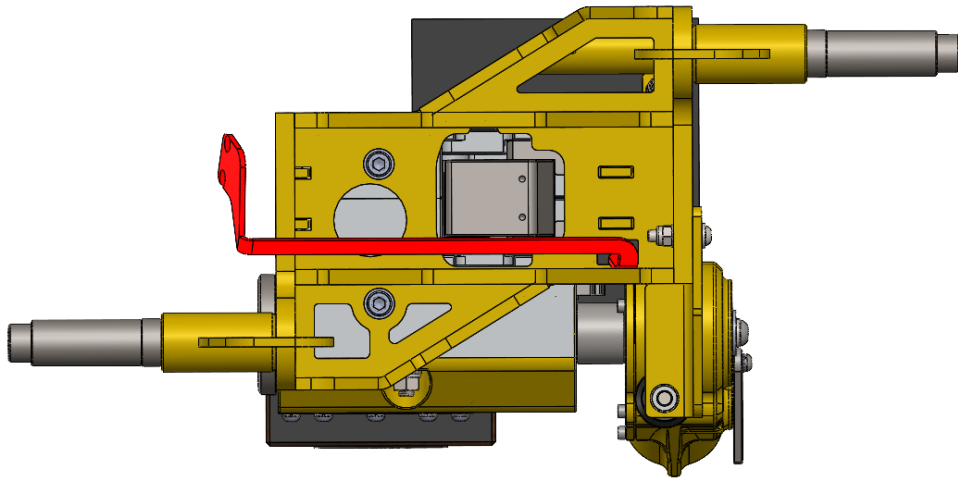

Figure 5

- c. With the block upside down and the gear rack all the way out, install the grab assembled according to MM AM-HDM-145-K01/2-6. See Figure 6.

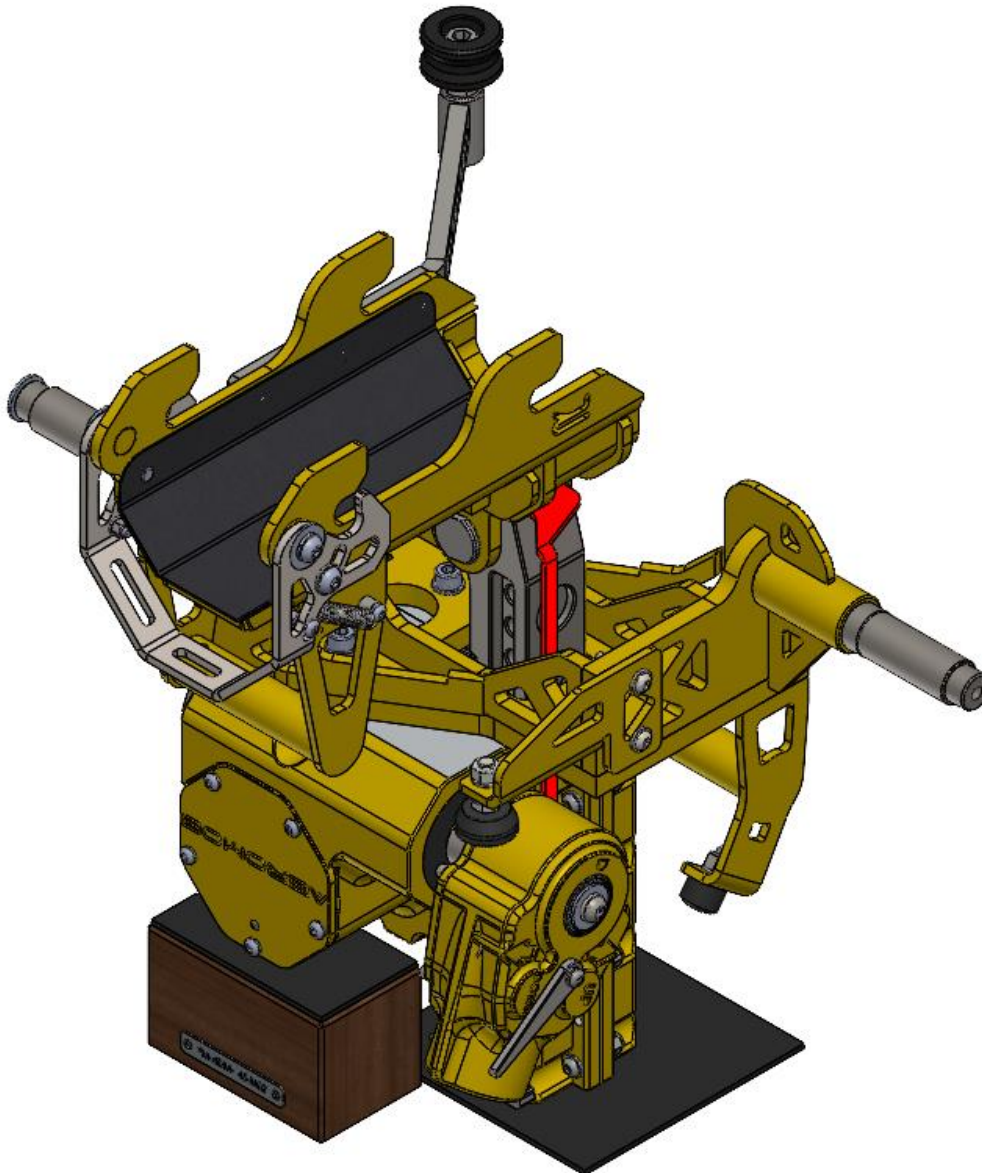

Figure 6

- d. With the block upside down and the gear rack all the way out, install the assembled wheels according to MM-AM-HDM-145-K01/4-3. See Figure 7.

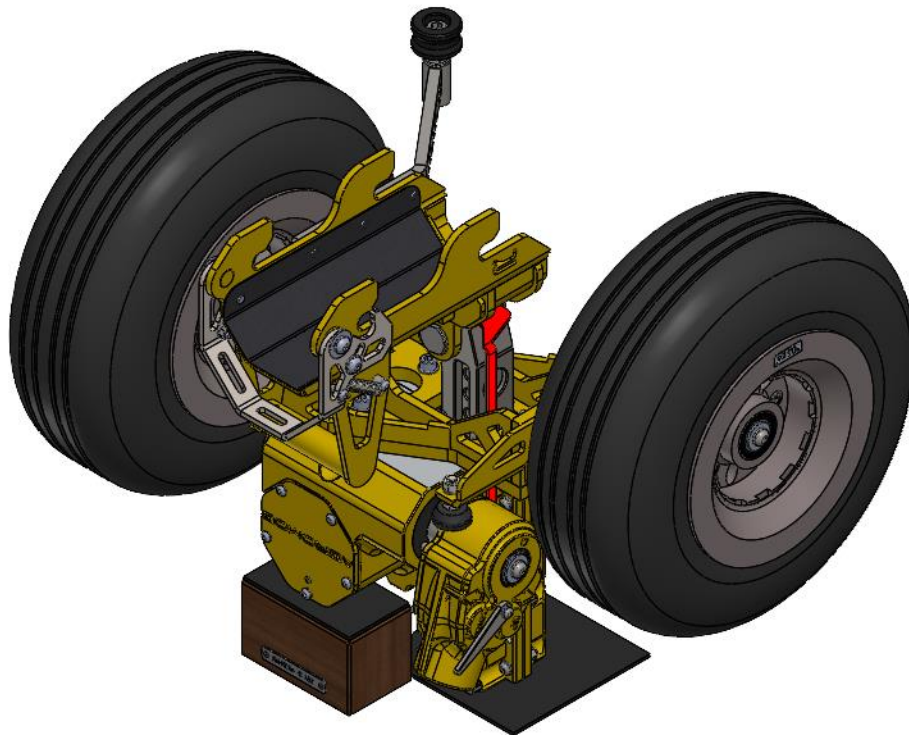

Figure 7

- e. With the rack gear all way out, base, grab and wheels mounted, put the equipment upside up, install part (1-4/19) along with (1-4/23).
- f. With the assembly fully assembled and wheels supported on the bench, insert the assembled lever bar according to MM-AM-HDM-145-K01/4-4.
- g. Take the equipment to the aircraft and lock it to the Skid.
- h. Put the ratchet handle selector lever (5-3/8) in the UP position.

- i. One operator must lock the screw (1-4/21) with a wrench while another operator positions the hook scale on the lever bar. The position must be 720 mm in relation to the center of the ratchet handle, as shown in Figure 8. The operator must pull the lever bar, repeating the movement until the scale registers 21 Kgf.

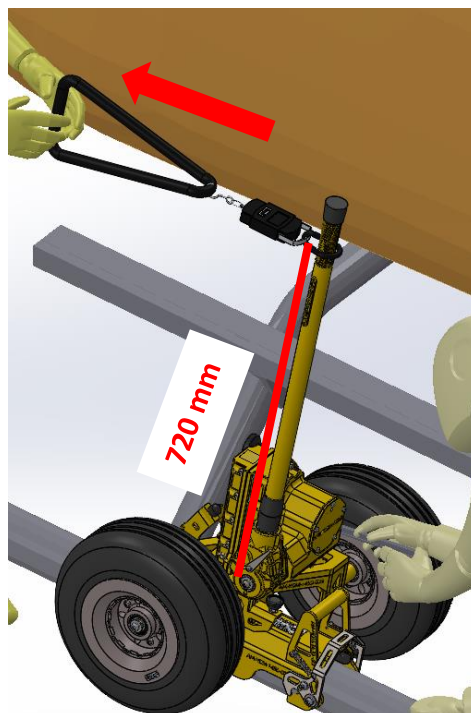

Figure 8

- j. Remove the equipment from the aircraft and store it for 24 hours to dry the thread lock glue.

- k. **PROHIBIT** the use of the equipment for 24 hours after this procedure.

INTENTIONALLY BLANK

Disassembly / Assembly - BODY

MM AM-HDM-145-K01/4-1

A. Applicable Documents

- a. IPC AM-HDM-145D-K01.

B. Specials Tools

- a. FM-HDM-145-010 – Worm gear puller tool.
- b. FM-HDM-145-011 – Pulling tool punch
- c. Hydraulic Press 15 ton.

C. Materials

- a. Bicomponent lubricant AM-LUB-01, volume 180ml.

D. Routine Spare Parts

- a. Gasket AM-HDM-145D-037 according to (1-4/13).

E. Work Setup

- a. Prepare a clean, rubberized, and organized workbench.
- b. Clean the equipment as described in MM AM-HDM-145-K01/3-1.

F. Disassembly procedure

- a. Execute card MM AM-HDM-145-K01/1-0 section F, **paragraph a to k** to separate the body from other components of the equipment AM-HDM-145D-K01.

- b. Position the block with the Front Cover (1-4/8) facing up.
- c. Remove eight screws (1-4/53).
- d. Drain the bicomponent lubrication.
- e. Remove the anti-vacuum screw (1-4/54).
- f. Using two flat screwdrivers, use the side slots to pry the front cover out (1-4/8).
- g. Loosen and remove the screws (1-4/44) and other washers belonging to the assembly.
- h. Remove items (1-4/12), (1-4/17) and (1-4/18).
- i. Loosen and remove the screw (1-4/21), washer (1-4/10).
- j. Position the FM-HDM-145-001D base on the press and place the block on it.
- k. Insert the bushing into the press shaft.
- l. Activate the press on the worm shaft (1-4/6) until it moves 1 to 2 mm. Monitor the strength so that it does not exceed 500 kgf. Turn the worm shaft manually to unlock it from the worm gear. Repeat this operation until the worm shaft is completely removed.
- m. Remove the bearing (1-4/30).
- n. Remove the worm gear (1-4/7) using the worm gear puller tool FM-HDM-145-010 and the pulling tool punch FM-HDM-145-011.
- o. Clean the worm gear with kerosene using a brush, inside a bowl.
- p. Inspect the worm gear teeth.
- q. Remove the keys (1-4/20) by pressing the end closest to the shaft end.

- r. With the block (1-4/5) on the bench and with the cavity facing down, remove the screws (1-4/40) and the cover (1-4/1) from the block.
- s. With the cover (1-4/1) on the bench with the inside facing up, remove the rack guide (1-4/2) by loosening the screws (1-4/47), and removing the washers belonging to it to the whole.
- t. Remove the retaining washer (1-4/25) and bearing (1-4/39) from the end of the shaft (1-4/16).
- u. Remove the gear rack (1-4/4), pinion (1-4/3) and keys (1-4/20) by pressing them on the end closest to the shaft.
- v. Remove the rack guide (1-4/2) from the block (1-4/5).
- w. Disassembly of each worm shaft component is detailed in MM AM-HDM-145D-K01/4-7.
- x. Remove seals (1-4/13) and (1-4/24) from cover (1-4/8).
- y. Clean all parts with kerosene.

INTENTIONALLY BLANK

G. Assembly procedure

- a. Install the wheel seal (1-4/35) in the block (1-4/5), after installing the outer ring of the bearing (1-4/30), on the right side of the block and the outer ring of the other bearing (1- 4 /30) on the left side of the block. According to Figure 9.

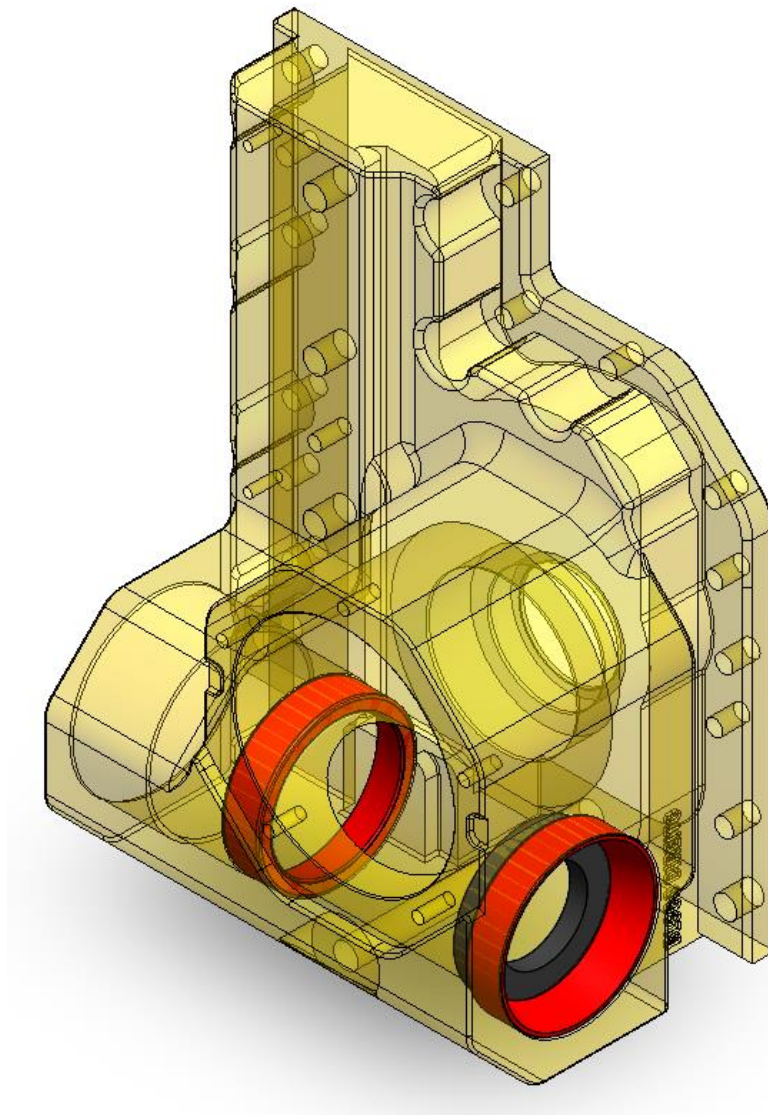

Figure 9

- b. Position the gear rack guide (1-4/2) on the block (1-4/5). Position the parts (1-4/17) and (1-4/18). Using the screws (1-4/44) and washers belonging to this step, tighten the components mentioned above.
- c. Install the bearing (1-4/39) on the shaft (3-4/16), then install the wheel seal (1-4/33) using petroleum jelly on the same shaft. (Make sure the open side of the seal is facing the bearing and the inner edge of the seal is not bent).
- d. Insert the shaft with the bearing and seal already assembled through the front of the block using petroleum jelly on the outer face of the seal and on the sealing bed in the block.
- e. Position the block with the inside facing up, insert the retaining washer (1-4/25). Insert the 4 keys (1-4/20) into the shaft (1-4/16). The inclined face of the key must face the tip of the shaft, as shown in Figure 10.

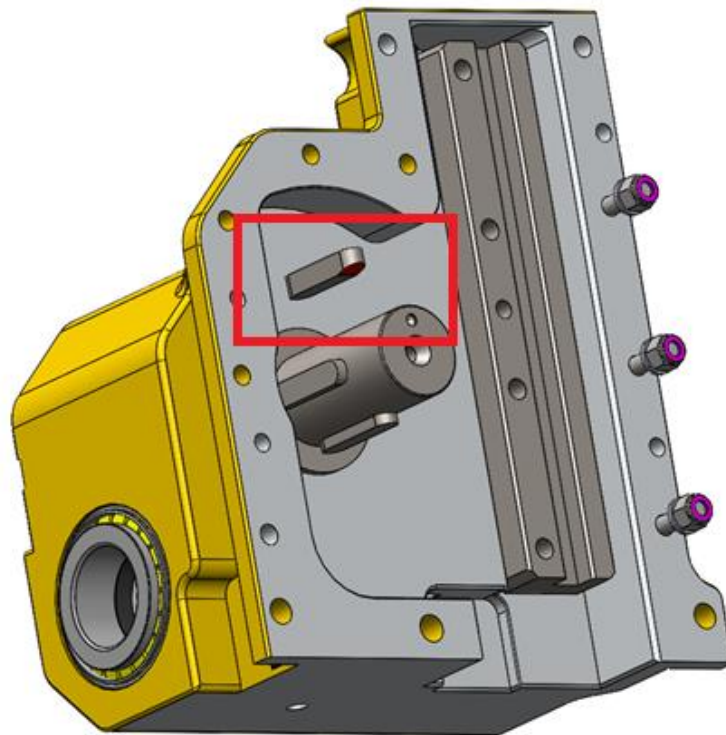

Figure 10

- f. Insert the pinion (1-4/3) into the shaft (1-4/16) ensuring that the mounting markings are aligned.

- g. Turn the pinion clockwise until the limit of the block, fit the gear rack so that the first tooth of the gear rack (1-4/4) overlaps the first tooth of the pinion, according to the Figure 11.

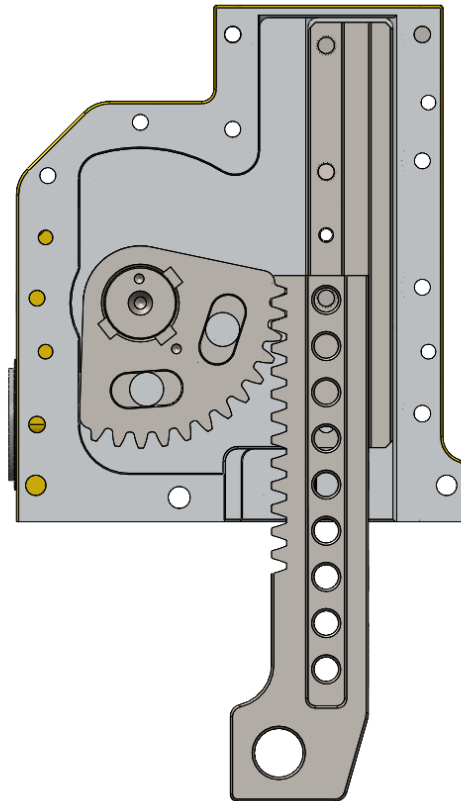

Figure 11

- h. With the gear rack already fitted, move the gear rack up and down in its full stroke, ensuring that there is no interference. (If there is an obstruction, some maintenance may be necessary before the assembly sequence).
- i. Once the gear rack is delivered completely, free and without play, remove the gear rack to apply AM-LUB-GX12 grease to the gear rack teeth and the grooves where the guides will run. Also apply the same grease to all faces of the guide (1-4/2), the teeth and sides of the pinion (1-4/3).
- j. Insert the other spacer (1-4/25) and bearing (1-4/39) into the end of the shaft (1-4/16).

- k. With the cover (1-4/1) on the bench with the inner and outer part facing up, install the other guide (1-4/2) using the screws (1-4/42), together with the washers belonging to the assembly.
- l. Apply AM-LUB-GX12 grease to all faces of the guide (1-4/2) mounted on the cover (1-4/1).
- m. With the block (1-4/5) on the bench and with the inner and outer part facing upwards, fit the cover (1-4/1) onto the block.
- n. With the block and rear cover well fitted, check that the gear rack movement (1-4/4) has full movement, free and without play. (If there is an obstruction, some maintenance may be necessary before the assembly sequence).
- o. Once the gear rack is delivered completely, free and without play, insert the screws (1-4/40) and the other washers belonging to the assembly, tightening in criss-cross pattern.
- p. With the rear cover (1-4/1) lying on the bench, ensure that the gear rack runs completely, freely and without play. (If the movement is obstructed, there may have been misalignment in the assembly between the cover and the block, in this case, loosen the screws seeking better alignment before retightening).
- q. With the rear cover (1-4/1) lying on the bench, install the 4 keys (1-4/20) on the shaft (1-4/16). See Figure 12.

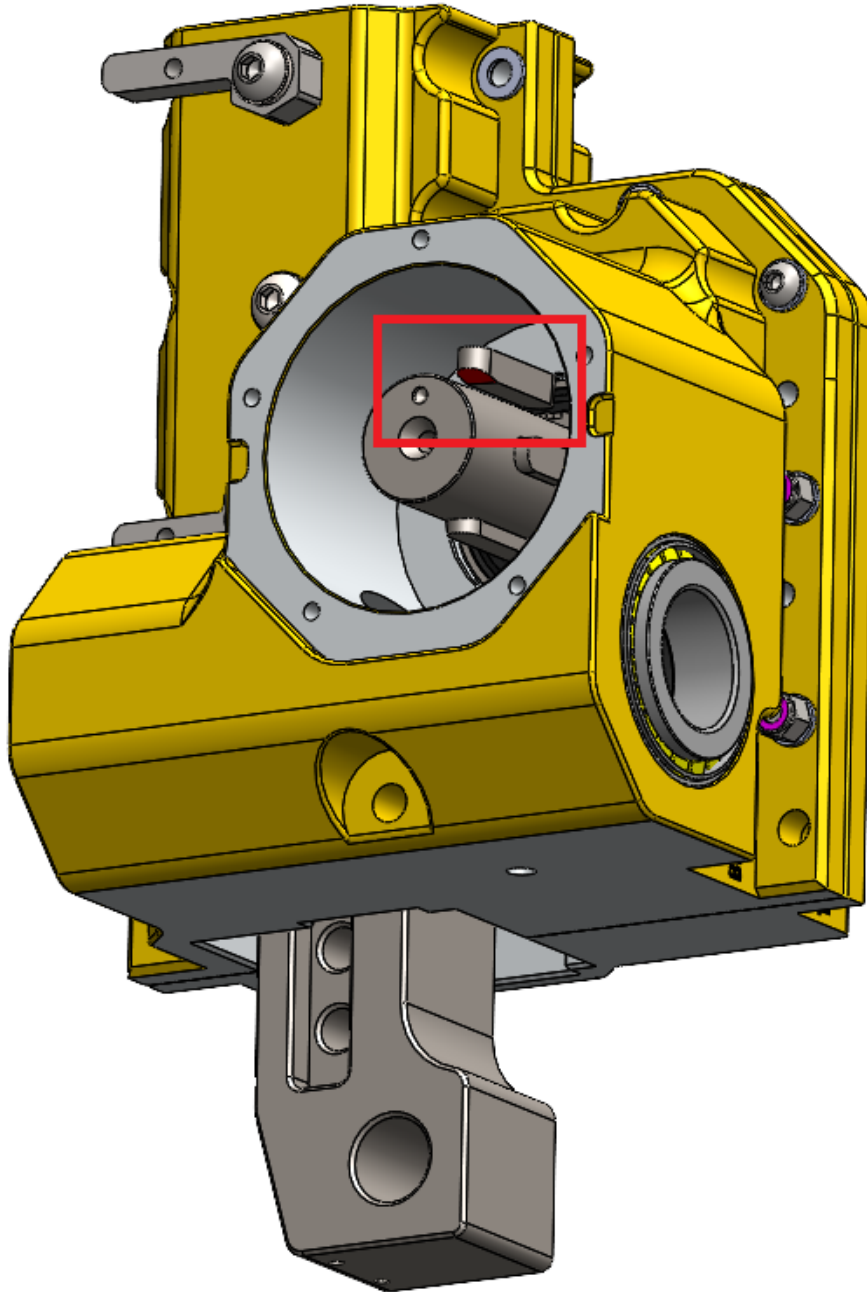

Figure 12

- r. Insert the worm gear (1-4/7) ensuring the mounting markings between the worm gear and shaft are aligned.

- s. Before starting this step, ensure that the gear rack (1-4/4) is fully retracted as shown in Figure 13. (If you try to assemble the next step with the rack out of this position, the worm gear will not have the ability to rotate during the worm shaft assembly and gear teeth will be severely damaged.)

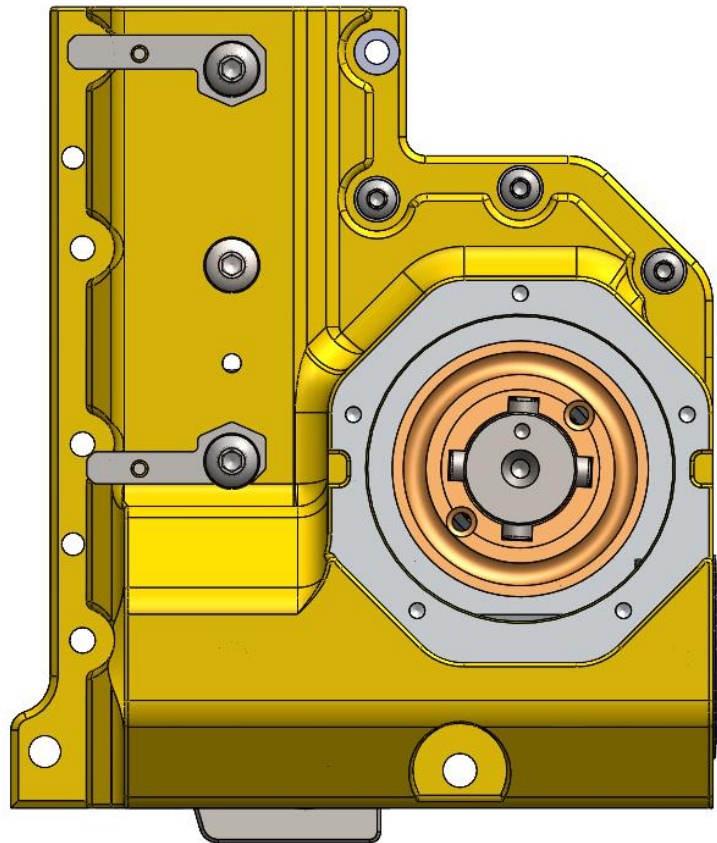

Figure 13

- t. With the worm shaft (1-4/6) assembled according to MM-AM-HDM-145D-K01/4-7, insert it through the left side of the block in a centered and connected manner, rotating and pushing the worm shaft, making the worm shaft teeth turn the worm gear teeth and the gear rack descends. Use the FM-HDM-145-F02 tool to hit the bearing (1-4/31) mounted on the worm shaft (1-4/6) to fit the worm shaft into the block until the end of the worm shaft course.

- u. Insert the bearing (1-4/30) into the right side of the block. Apply a little AM-LUB-GX12 grease to one side of the item (1-4/11) and place it centered on the washer (1-4/10).
- v. Apply plenty of TB1375 thread lock glue to the screw (1-4/21) and the corresponding threaded hole.
- w. With the equipment on the bench position (1-4/10), assemble and tighten the screw (1-4/21).
- x. On the left side, insert the retainer (1-4/32), bushing (1-4/9), handle bearing (1-4/56) and keys (1-4/26). Use the tool FM-HDM-145-F03.
- y. Insert the assembled handle according to MM-AM-HDM-145D-K01/2-5 into the worm shaft, ensuring that the handle selector is centered in the neutral point before starting the fitting.
- z. Assemble items (1-4/27) and (1-4/57) on the ratchet handle.
- aa. Screw with (1-4/55) and other applicable washers using TB1375 thread lock glue on the screw thread.
- bb. Prepare the lubricant with 150 mL of oil and 30 mL of grease, both supplied by Aeromob. Mix the components well until a watery paste is formed.
- cc. With the rear cover (1-4/1) lying on the bench and the front part of the external block upwards, 180ml of AM-LUB-BI01 funding through the front opening of the block, filling the space in the force multiplier box where they are mounted the worm gear (1-4/7) and the worm shaft (1-4/6). Move the worm shaft by making the gear rack move up and down during the application of lubrication to ensure that the lubrication has entered between the gears and tapered bearings, making the 180ml of the aforementioned lubricant fit inside the box.
- dd. With the front cover (1-4/8) on the bench with the inner outer part facing up, install the gaskets (1-4/13) and (1-4/24) on the cover and the bearing (1-4/ 41).
- ee. Ensure the screw (1-4/54) has been removed from the front cover (1-4/8). Before placing the lid, put the lubricant and turn the ratchet handle up and down 10 times

until the end, to spread the lubricant. (Note: When assembling the front cover on the block, it is common to expel excess lubrication onto the front cover).

- ff. Insert the screws (1-4/53) with the respective washers into the front cover (1-4/8) and tighten crosswise.
- gg. With the front of the outer block facing up, install the part (1-4/12) and screws (1-4/42).
- hh. With the block upside down, insert the support tool FM-HDM-145-M02 so that the block does not tip over. Fit the assembled base according to MM AM-HDM-145-K01/2-2 and place the screw (1-4/15) with the washer belonging to the assembly, according to Figure 14.

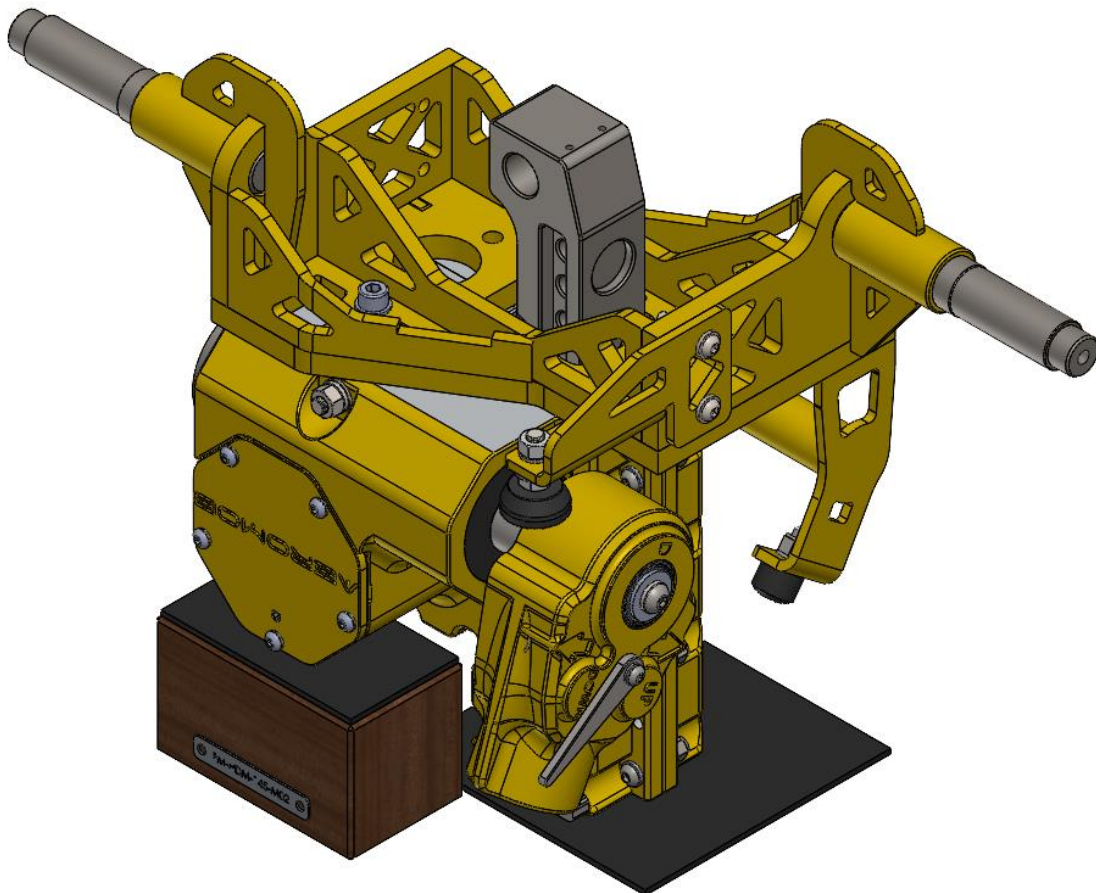

Figure 14

- ii. With the block upside down, tilt the arrow (1-4/14) towards the cover side (1-4/8) as shown in Figure 15. Position the tip of the arrow in the pit, as shown in the top

view of Figure 16. Carefully move the part into the mentioned pit and rotate it to a vertical position. Install screws (1-4/52).

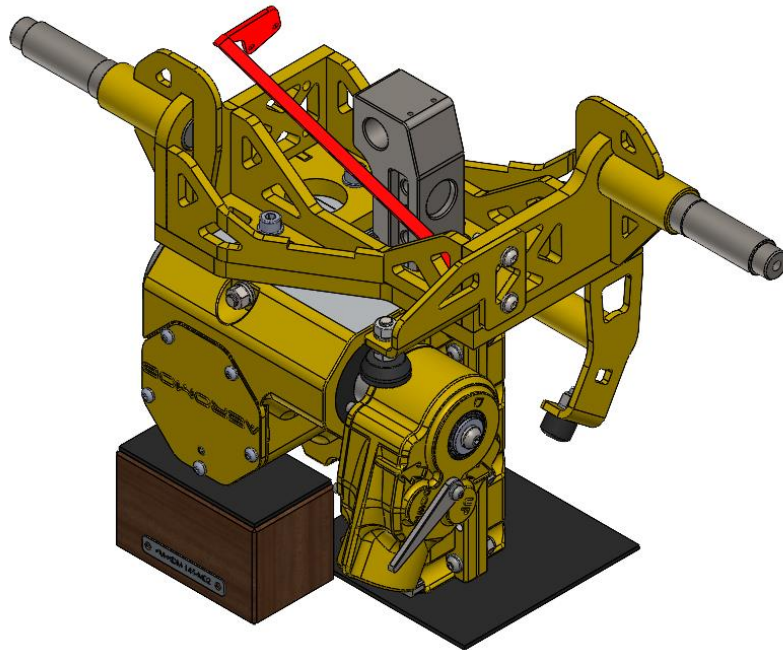

Figure 15

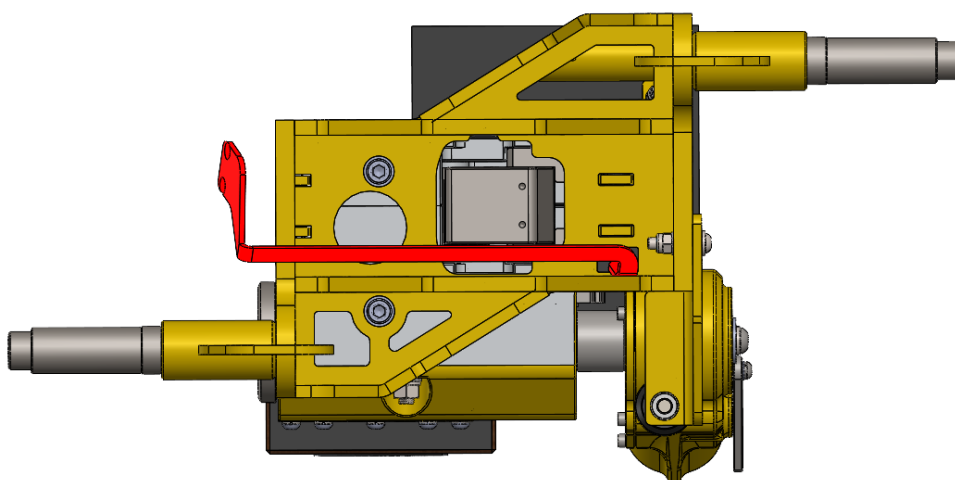

Figure 16

- jj. With the block upside down and the gear rack all the way out, install the grab assembled according to MM AM-HDM-145-K01/2-6, see Figure 17.

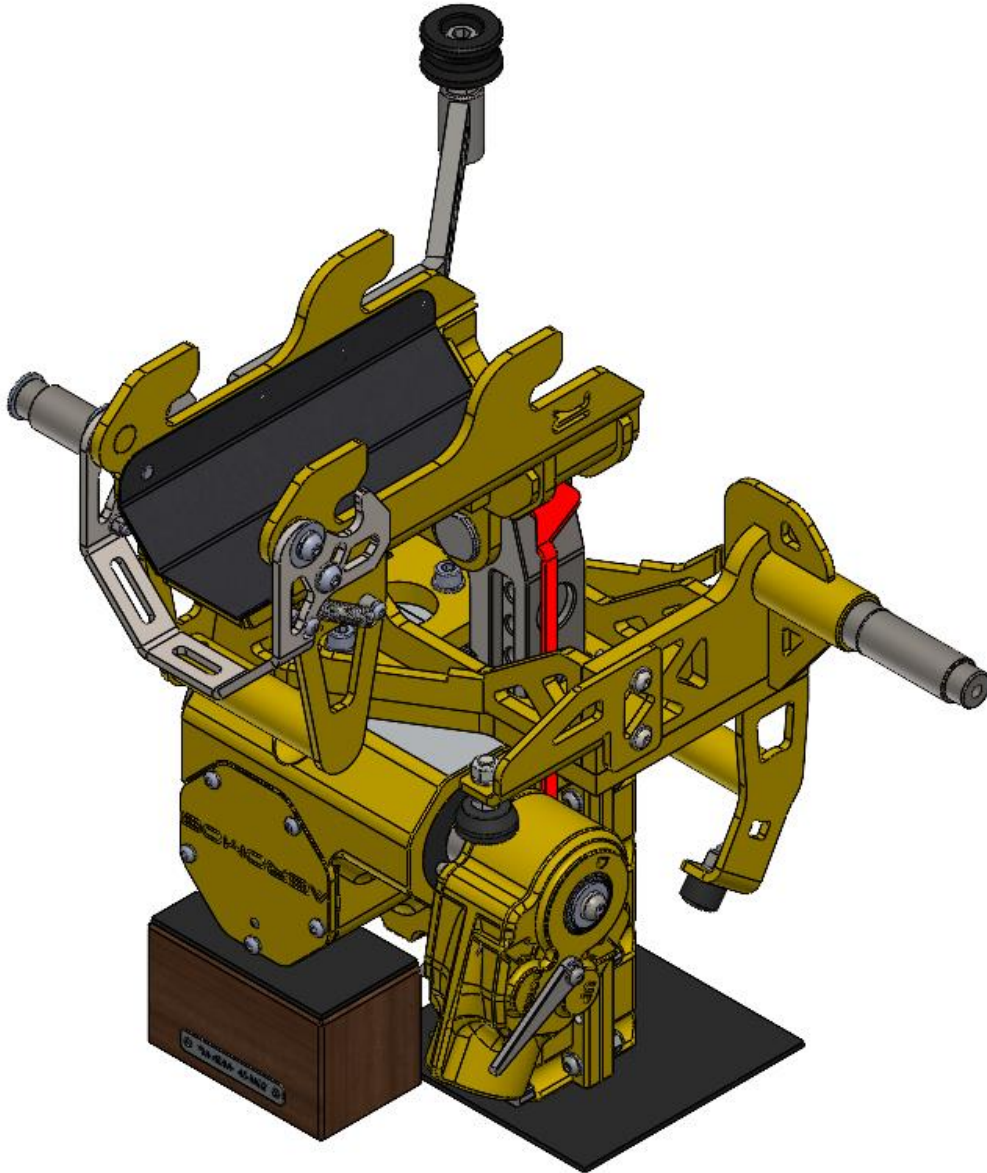

Figure 17

- kk. With the block upside down and the gear rack all the way out, install the assembled wheels according to MM-AM-HDM-145-K01/4-3. See Figure 18.

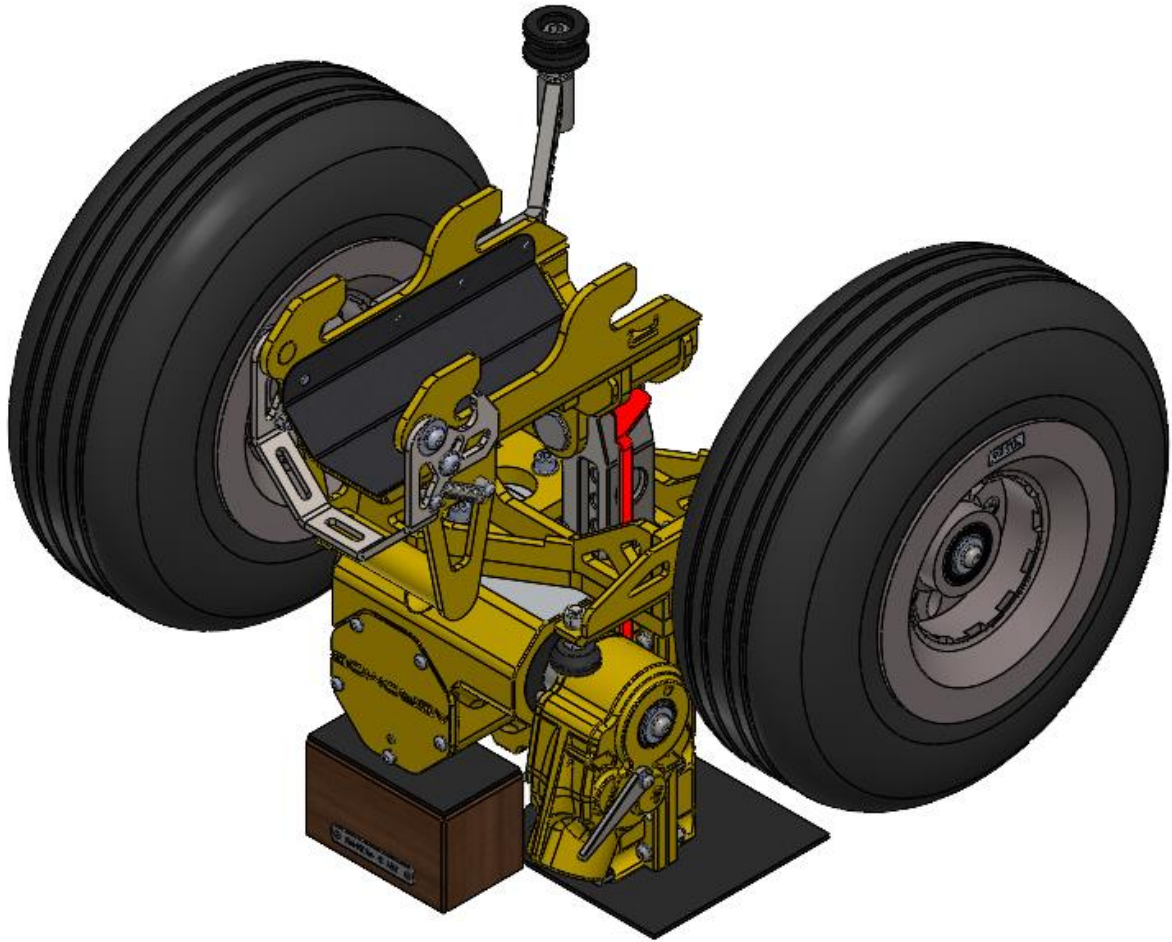

Figure 18

- II. With the gear rack all the way out, with the base, grab and wheels assembled, position the block upside down, install part (1-4/19) with (1-4/23).

mm. With the entire assembly assembled and wheels supported on the bench, place the assembled lever bar according to MM-AM-HDM-145-K01/4-4.

nn. To mount the body on the equipment, use the MM card AM-HDM-145D-K01/4-0 section G.

INTENTIONALLY BLANK

Disassembly / Assembly – BASE

MM AM-HDM-145-K01/4-2

A. Applicable Documents

- a. IPC AM-HDM-145D-K01.

B. Specials Tools

N/A

C. Materials

N/A

D. Routine Spare Parts

N/A

E. Work Setup

N/A

F. Disassembly procedure

- a. Separate the base from the rest of the equipment as described in MM AM-HDM-145-K01/4-0, section F, **paragraphs a to i**.
- b. Remove item (2-3/6) by loosening nut (2-3/10).
- c. Loosen the screws (2-3/9) and remove the part (2-3/2) and other components belonging to this step.
- d. Loosen the nut (2-3/4) and remove the part (2-3/5).
- e. Clean all parts with kerosene.

G. Assembly procedure

- a. Insert the part (2-3/5), the nut (2-3/4) and other components belonging to this step.
- b. Insert the part (2-3/2), the screws (2-3/9) and the other components belonging to this assembly.
- c. Assemble the item (2-3/6) with the nuts (2-3/10) and other components belonging to this step.
- d. Separate the screws (2-3/13), (2-3/14), (2-3/16) and other related nuts and washers, for later assembly into the complete set.
- e. To assemble the base to the rest of the equipment, see **paragraphs a, e, f** of the MM AM-HDM-145-K01/4-0 section G.

INTENTIONALLY BLANK

Disassembly / Assembly – WHEEL

MM AM-HDM-145-K01/4-3

A. Applicable Documents

- a. IPC AM-HDM-145D-K01

B. Specials Tools

- a. Hot air gun 1800W.
- b. Bearing puller tool.
- c. Hydraulic Press.

C. Materials

N/A

D. Routine Spare Parts

N/A

E. Work Setup

- a. Prepare a clean, rubberized and organized workbench.

F. Disassembly procedure

- a. To remove the wheels from the equipment, execute **paragraphs e to j** of section F on the MM AM -HDM-145-K01/4-0.
- b. With the wheel lying on the bench, use the bearing puller to remove them (3-1/6) e (3-1/7).
- c. Remove tire valve caps and slightly deflate the air chamber.

- d. Loosen the screws (3-1/8) and refill the air chamber to detach the two halves from the wheel (3-1/3) before completely emptying it again. With the tires still mounted and the air chamber completely empty, insert a spacer plate (without sharp edges) between the rims, as shown in

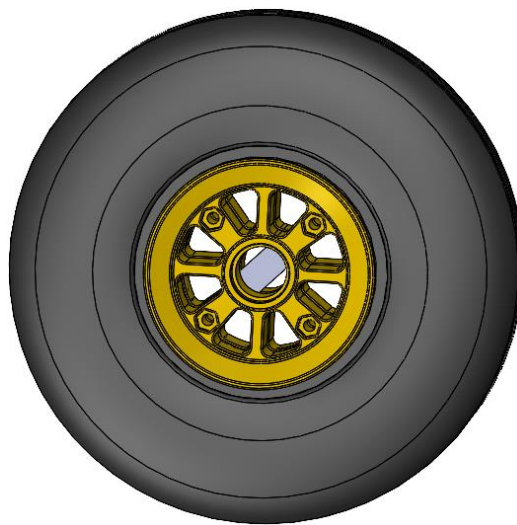

Figure 19

- e. Place the wheel in the hydraulic press and apply force to the spacer plate to detach the rim from the tire, until the rim is completely removed from the tire. As shown in Figure 21.

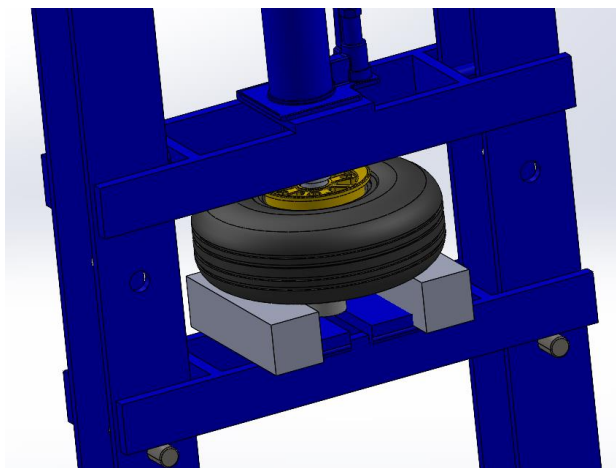

Figure 20

- f. Remove the air chamber (3-1/4) from inside the tire.

G. Assembly procedure

- a. Position the rim on the bench so that the smallest portion of the chamber valve passage diameter is below. See Figure 21.

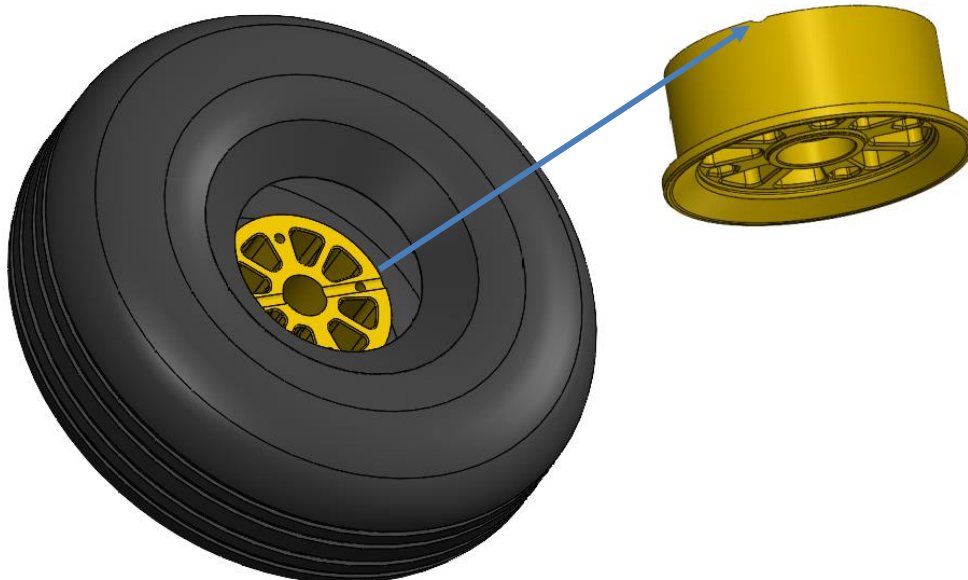

Figure 21

- b. Insert the air chamber inside the tire. Insert the tire with the air chamber over the rim and position the inflation valve in the smallest portion of the passage diameter.
- c. Insert the other half of the rim over the tire and ensure a good fit without crushing or damaging the inflation valve.
- d. Position the assembly in the hydraulic press and apply force to the rims, so that the two halves of the rim form a definitive fit. Protect the paintwork to prevent damage.
- e. Position the assembly on the bench again, mount the screws (3-1/8) and tighten.

- f. Assemble the bearings (3-1/7) e (3-1/6).
- g. Position the equipment on a clean, rubberized bench, with the end of the shaft vertical, using support block FM-HDM-145-M02.
- h. Place one of the wheels on the axle and apply thread lock glue to the hole threaded. Insert washers (2-3/12), (2-3/15) and screw (2-3/16).
- i. Rotate the equipment 180° and repeat the procedure above.
- j. To assemble the wheels on the equipment, follow **paragraphs a to d** of the MM AM-HDM-145-K01/4-0, section G.

Disassembly / Assembly – LEVER BAR

MM AM-HDM-145-K01/4-4

A. Applicable Documents

- a. IPC AM-HDM-145D-K01

B. Specials Tools

N/A

C. Materials

N/A

D. Routine Spare Parts

N/A

E. Work Setup

N/A

F. Disassembly procedure

- a. Pull the lever bar to remove it from equipment. Remove the spring plunger (4-3/2)
- b. Remove part (4-3/4)
- c. Remove the cover (4-3/3)

G. Assembly procedure

- a. Insert cover (4-3/3)
- b. Insert part (4-3/4)
- c. Insert spring plunger (4-3/2) e lever bar on ratchet handle.

Disassembly / Assembly – RATCHET HANDLE

MM AM-HDM-145-K01/4-5

A. Applicable Documents

- a. IPC AM-HDM-145D-K01

B. Specials Tools

N/A

C. Materials

N/A

D. Routine Spare Parts

N/A

E. Work Setup

N/A

F. Disassembly procedure

- a. Remove the ratchet handle according to MM AM-HDM-145-K01/4-0, executing the **paragraphs a, b, c, d e k** of section F.
- b. Loosen and remove screws (5-3/15)
- c. Remove cover (5-3/3).
- d. Drain all the oil.
- e. Position the selector lever (5-3/8) in the neutral position and remove the gear (5-3/5).
- f. Remove components (5-3/9), (5-3/10) and (5-3/13).
- g. Remove pin (5-3/16) and separate items (5-3/1) and (5-3/2).

- h. Loosen and remove the screw (5-3/12) to remove the ratchet handle bushing (5-3/6).
- i. Remove items (5-3/4) and (5-3/7).
- j. Clean the parts with kerosene.

G. Assembly procedure

- a. Assemble the shaft (5-3/1) with the part (5-3/2) by inserting the pin (5-3/16).
- b. Insert the ratchet handle bushing (5-3/6) by screwing it with (5-3/12).
- c. Position the ratchet handle body (5-3/7) with the cavity facing up.
Position the ratchet handle gear (5-3/5) with the center of the ratchet handle body.
- d. Place the bushings (5-3/4) into the ratchet handle body housings.
- e. Insert the shafts (5-3/10) into the bushings (5-3/4) already assembled.
- f. Insert the grabs (5-3/9) into the axles (5-3/10) already assembled.
- g. Position the springs (5-3/13) inside the grab holes (5-3/9).
- h. Position the shaft (5-3/1) in the central bushing (5-3/4) already mounted on the ratchet handle body. Screw the item (5-3/14) and other components belonging to this step with (5-3/9).
- i. Place the 3 bushings (5-3/4) concentric with the recesses in the cover (5-3/3).
- j. Insert screws (5-3/15) applying torque in a criss-cross pattern.
- k. To insert the ratchet handle into the equipment, follow **paragraphs a to d** of the MM AM-HDM-145-K01/4-0 section G.

Disassembly / Assembly – GRAB

MM AM-HDM-145-K01/4-6

A. Applicable Documents

- a. IPC AM-HDM-145-K01.

B. Specials Tools

- a. Hot air gun 1800 W.

C. Materials

- a. Thread lock glue

D. Routine Spare Parts

N/A

E. Work Setup

N/A

F. Disassembly procedure

- a. To remove the grab from the assembled equipment, follow **paragraphs a to g** of section F on the card MM AM-HDM-145-K01/4-0.
- b. Remove the pin (6-3/7) with the elements (6-3/19), (6-3/13) and (6-3/18).
- c. Remove the grab support (6-3/3) with the other items belonging to the assembly.
- d. Remove items (6-3/15), (6-3/22) and (6-3/9) and other items belonging to this step.
- e. Remove screws (6-3/16) and bracket (6-3/2).

- f. Remove grab lock (6-3/4) and items (6-3/10), (6-3/11), (6-3/13) and (6-3/17).
- g. Remove the anti-abrasive protection (6-3/5) that is glued to the bottom of the grab.

G. Assembly procedure

- a. Position the grab lock (6-3/4) and the items (6-3/10), (6-3/11), (6-3/13) and (6-3/17).
- b. Assemble the spring (6-3/9) together with the items (6-3/6), (6-3/12) and (6-3/14), (6-3/22) and other components. tighten the screws.
- c. Assemble items (6-3/2) with screws (6-3/16).
- d. Insert the grab support (6-3/3) with the other items belonging to the assembly.
- e. Position the pin (6-3/7) with the elements (6-3/19), (6-3/13) and (6-3/18).
- f. Glue an anti-abrasive protection (6-3/5) to the bottom of the grab.
- g. To mount the grab on the equipment, follow the procedures described in **paragraphs a to g** of the card MM AM-HDM-145-K01/4-0 section G.

Disassembly / Assembly – WORM SHAFT

MM AM-HDM-145-K01/4-7

A. Applicable Documents

- a. IPC AM-HDM-145-K01.

B. Specials Tools

- a. Spanner KM lock nut
- b. Bench Vice
- c. Bearing puller tool

C. Materials

N/A

D. Routine Spare Parts

N/A

E. Work Setup

N/A

F. Disassembly procedure

- a. To remove the worm shaft from the rest of the equipment, read the card MM-AM-HDM-145D-K01/4-, Section F, **paragraphs a to l**.
- b. Remove the bearing (1-4/31) using the bearing puller tool.
- c. Unlock the washer tooth (1-4/50) of the external KM nut.
- d. Remove the KM nut (1-4/51) using the spanner KM lock nut.
- e. Remove one washer (1-4/50). Remove another KM nut.

- f. Remove only the tapered bearing body (1-4/30) from the worm shaft (1-4/6).
- g. Remove the worm shaft (1-4/6) from the bench vice.
- h. Clean all parts with kerosene.

G. Assembly procedure

- a. Place the (1-4/6) in the bench vise in an upright position. The vise must have aluminum jaws so as not to mark or damage the worm shaft. Never fasten a part by the thread face.
- b. Position the bearing body (1-4/30) on the worm shaft with the tapered side facing inward.
- c. Position one of the KM nut (1-4/51) and tighten with the spanner KM lock nut. Install the internal tooth lock washer (1-4/50).
- d. Position another KM nut and tighten.
- e. Lock one washer tooth (1-4/50) onto the outer KM nut.
- f. Assemble the bearing (1-4/31) using tool FM-HDM-145D-F05.
- g. To mount the worm shaft to the rest of the equipment, apply procedure MM AM-HDM-145-K01/4-1, Section G **paragraph dd**.

TROUBLESHOOTING

FAILURE LIST

SYMPTOM	EFFECT	POSSIBLE CAUSES	MAINTENANCE CARD
Equipment descends on its own when the operator is activating the lever bar of the equipment to lower the helicopter.	Screw (1-4/21) came loose.	Operator turned it down over the limit.	MM AM-HDM-145-K01-TS1
Flat tire.	Leaky air chamber.	Sharp materials on the route.	MM AM-HDM-145-K01-TS2

Lift System Failure

MM AM-HDM-145-K01/TS-1

A. Applicable Documents

- a. IPC AM-HDM-145D-K01

B. Specials Tools

- a. Hot air gun 1800 W.
- b. Hook scale.

C. Materials

- a. Thread lock glue TB1375.

D. Routine Spare Parts

N/A

E. Work Setup

N/A

F. Disassembly procedure

- a. To loosen the screw (1-4/21), read the card MM AM-HDM-145-K01/4-0 Section F, **paragraph a to h**.

- b. Use the hot air gun (1800 W for 2 minutes) to remove the thread lock glue from the screw (2-3/16) on the same side as the screw (1-4/21).
- c. Remove the wheel mentioned above.
- d. While one operator holds the equipment, the other operator completely removes the screw in question. Pay attention to the screw thread, for left-hand equipment, the screw has a left-hand thread.

G. Assembly procedure

- a. Read the card MM AM-HDM-145-K01/4.1 section G **paragraphs dd, ee, gg, hh.**
- b. Place the wheel back on the equipment, apply thread lock glue to the screw (2-1/18) and tighten it with the washers belonging to this assembly.
- c. Read the card MM AM-HDM-145-K01/4.1 section G **paragraphs g, h, i, j and k.**

Flat Tire

MM AM-HDM-145-K01/TS-2

A. Applicable Documents

- a. IPC AM-HDM-145D-K01

B. Specials Tools

- a. Hot air gun 1800 W.
- b. Bearing puller tool.
- c. Hydraulic press 15 ton.

C. Materials

- a. Thread lock glue TB1375.
- b. air chamber (3-1/4).

D. Routine Spare Parts

N/A

E. Work Set-up

N/A

F. Disassembly Procedure

- a. To remove the wheels from equipment, execute the card MM AM-HDM-145-K01/4-0 Section F, **paragraph e** to **paragraph j**.
- b. Execute o cartão MM AM-HDM-145-K01/4-3, **alínea e** até **alínea g**, seção F.

G. Assembly Procedure

- a. To assemble the wheel, execute card MM-AM-HDM-145-K01/4-3, section G **paragraph a** to **paragraph e**. Also execute **paragraph g** to **paragraph i**.